

# Stormwater Management Guidance



WHERE COMMUNITY AND SPIRIT MEET®

## City of Kirkwood Green Infrastructure Techniques for Stormwater Management

November 2018



Prepared by:  
Wood Environment & Infrastructure Solutions, Inc.



## TABLE OF CONTENTS

---

BACKGROUND AND PURPOSE .....	1
REQUIREMENTS AND PRINCIPLES OF STORMWATER MANAGEMENT .....	2
SUBMITTAL INFORMATION.....	3
MAINTENANCE AND INSPECTIONS.....	4
DRY WELLS .....	5
VEGETATED FILTER STRIP AREAS .....	9
MODIFIED FRENCH DRAIN .....	14
PERMEABLE PAVERS .....	18
RAIN GARDENS.....	22
CREDIT FOR EXISTING TREES.....	26
APPENDIX A – INFILTRATION TESTING	
APPENDIX B – RECOMMENDED PLANTS - RAIN GARDENS	
APPENDIX C – DETERMINING FLOW AREA	
APPENDIX D – UNDERDRAINS	
APPENDIX E – INFILL DEVELOPMENT ORDINANCE	



## BACKGROUND AND PURPOSE

Land development permanently alters the way in which stormwater flows across a site due to grading, compaction, and the installation of impervious cover. In an attempt to reduce these impacts, the City of Kirkwood requires, in accordance with Municipal Code *Chapter 5, Article VI. Infill Development Storm Water Management*, that stormwater management measures be utilized when constructing a new home or addition that creates greater than 1,000 square feet of new impervious surface or causes the total impervious area to be twenty-five (25) percent or greater of the total lot area.

The purpose of this document is to provide guidelines for selecting and installing the appropriate stormwater management measures when constructing a home. The City acknowledges these regulations will not solve all stormwater related issues within the City; however, this is a reasonable effort to reduce impacts of development on stormwater.

This guideline employs simplified design standards more applicable to the homeowner/builder experience, thus avoiding the necessity for complex engineering calculations and analysis. This guideline is meant to complement the use of the Metropolitan St. Louis Sewer District (MSD) Rules and Regulations and Engineering Design Requirements for Sanitary Sewer and Stormwater Drainage Facilities, February 2018, or most current version, which must be used for sites that propose more than one (1) acre of land disturbance.

The City reserves the right to:

- Require a Professional Engineer (PE) seal on the drawings, and/or
- Require MSD review and approval of certain projects that are less than one (1) acre of land disturbance.



## REQUIREMENTS AND PRINCIPLES OF INFILL RESIDENTIAL STORMWATER MANAGEMENT

The following section provides, in a question and answer format, the necessary information for understanding the requirements and process for submittal.

### What types of residential projects require Stormwater Management?

The following activities are required to install stormwater management Green Infrastructure Practices / Best Management Practices (BMP) on site:

- Projects creating one thousand (1,000) square feet or more of net additional impervious area
- Projects causing the total impervious area on the lot to be twenty-five (25) percent or greater

### What are the principles for managing stormwater on residential developments?

Residential developments are not required to provide the same types of stormwater management as commercial projects; however, certain requirements must be met to ensure that stormwater runoff does not overwhelm existing stormwater infrastructure; impact water quality in our streams; or impact adjacent property. The key principles for managing stormwater from a residential lot are:

- Proper grading and erosion control techniques during construction;
- Reliance on infiltration only where the water table or bedrock layer is at least two feet below the bottom of the practice in use; and,
- Proper installation and maintenance of downspouts, channels, or any other sources of concentrated flow;
- Runoff reduction (see section below).

### What is Runoff Reduction?

The term 'Runoff Reduction' means the interception, evapotranspiration, infiltration, or capture of stormwater runoff. Examples of runoff reduction techniques on a single family residential development include any appropriate combination of the following techniques termed Green Infrastructure Practices:

1. Routing downspouts to underground dry wells,
2. Directing sheet flow to adequately sized vegetated filter strips / areas (also known as Amended Soil), or any appropriate combination of techniques'
3. Routing downspouts to modified French drains, or
4. Replacing traditional impervious surfaces (driveways, patios, etc.) with pervious paving,
5. Installing a rain garden or bioretention area.

The goal of these techniques is to reduce the volume of runoff generated by the first 1.14 inches of rain. Other BMPs that employ runoff reduction techniques may be used in lieu of these techniques with proper documentation of design criteria and details.

### How are Runoff Reduction techniques sized on residential developments?

Applicants can meet this requirement by following the practices in this technical guidance document to design an appropriate stormwater management plan. The amount of volume to be reduced on site is directly related to the drainage area contributing runoff to the treatment technology.



## SUBMITTAL INFORMATION

### What needs to be submitted?

In addition to any submittal requirements as specified by the City's permit submittal process, applicants must develop a site plan that includes the following items:

- Existing and proposed ground contours and elevations;
- Sanitary and storm sewer structures and easements;
- Location, configuration, and finished floor elevations for existing and proposed building structures;
- Location, configuration, and finished elevations for existing and proposed paved areas;
- Erosion and sediment control practices in conformance with the City Code.
- Site infiltration test results, tear-off sheet is included in Appendix A of this document.

Pertinent to stormwater, the following guidance applies to all designs -

- Stormwater runoff from the first 1.14 inches of rainfall must be captured on site and dissipated through the use of infiltration, evapotranspiration or alternate use (e.g. irrigation). It cannot run off the site.
- Concentrated stormwater discharge from a downspout or any collection device shall be located a distance of no less than 10 feet from any common property line.
- Details of all Green Infrastructure Controls/BMPs shall be attached to the site plan using, where possible, specification sheets from this document or sets of plans of equal detail and coverage.
- Should you choose not to perform infiltration testing as outlined in Appendix A, your site infiltration rate will automatically be recorded as 0.05 in/hr which excludes some BMP's as being applicable and others will require an underdrain. See Appendix D for details on constructing an underdrain.

### What is in the rest of this document?

The remainder of the document contains:

- (1) A set of six information/specification sheets, one for each of the six recommended Green Infrastructure Controls/BMPs. For each, the last two pages are a tear-off set of specifications that can be filled in and stapled to construction plans.
- (2) Appendix A that describes how to conduct infiltration testing.
- (3) Appendix B that describes the types of vegetation recommended for those Controls that feature vegetation as part of the treatment approach.
- (4) Appendix C that describes how to determine adequate flow area.
- (5) Appendix D that provides details if an underdrain is required.
- (6) Appendix E is the ordinance these guidelines are based upon.



## MAINTENANCE AND INSPECTIONS

- Each of the six Green Infrastructure Controls/BMPs information/specification sheets contains information regarding general maintenance that is required for each BMP.
- Inspections will be conducted by the City at the following intervals:
  - During construction,
  - One-year after construction of the BMP is completed, and
  - Three-year intervals after the one-year inspection.
- See the Operations & Maintenance Manual for additional maintenance information and inspection checklists. To view these and other helpful information visit the City website at [www.kirkwoodmo.org](http://www.kirkwoodmo.org).

## DRY WELLS

Dry wells are seepage tanks set in the ground and surrounded with stone. They are designed to intercept and temporarily store stormwater runoff until it infiltrates into the soil. Alternatively, the pit can be filled with stone where water will flow in via a perforated standpipe in place of the tank.

Dry wells are well-suited to receive rooftop runoff entering the tank via an inlet grate (shown at right) or a direct downspout connection (below right). When properly sized and laid out, dry wells can provide significant reductions in stormwater runoff and pollutant loads. **If an infiltration rate measured in accordance with Appendix A is less than 0.25 in/hr, a dry well is not suitable for your site.**

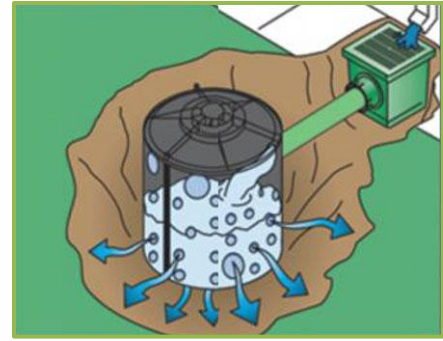

Source: [www.earthcontactproducts.com](http://www.earthcontactproducts.com)

## LOCATION

- Dry wells must be located at least 10 feet from building foundations and 10 feet from property lines.
- To reduce the chance of clogging, dry wells should drain only impervious areas, and runoff should be pretreated with at least one of the leaf removal options to remove debris and larger particles.
- The height of the tank should not exceed 72 inches unless infiltration testing has been done to ensure a drain time of 72 hours or less.
- Dry wells should be located in a lawn or other pervious (unpaved) area and should be designed so that the top of the dry well is located as close to the surface as possible.
- NOTE: Dry wells should not be located: (1) beneath an impervious (paved) surface; (2) above an area with a water table or bedrock less than two feet below the trench bottom; (3) over other utility lines; or, (4) above a septic field. Always call Missouri One Call to locate utility lines before you dig.



## CONSTRUCTION

- Consider the drainage area size and the soil infiltration rate when determining the size of the dry well, (see table on next page).
- The sides of the excavation should be trimmed of all large roots that will hamper the installation of the permeable drainage fabric used to line the sides and top of the dry well.
- The dry well hole should be excavated 1 foot deeper and two feet larger in diameter than the well to allow for a 12 inch stone fill jacket.
- The native soils along the bottom of the dry well should be scarified or tilled to a depth of 3 to 4 inches.
- Fill below and around dry well approximately 12 inches of clean, washed ASTM No. 57 stone. No.57 stone averages ½ inch to 1-½ inches.
- Fill the final 6 inches of the excavation with native soil, pea gravel, or ASTM No. 8 stone.
- For rooftop runoff, install a leaf screen in the gutter or downspout prior to entering the dry well to prevent leaves and other large debris from clogging the dry well. For non-rooftop runoff, precede the dry well with an in-ground sump grate or inlet leaf trap.
- An overflow, such as a vegetated filter area or grass channel, should be designed/provided to safely convey the stormwater runoff generated by larger storm events bypassing the dry well.
- The optional design involves placement of a vertical standpipe connected to the inlet pipe.

The table below can be used to size a dry well system. For a given tank height and diameter the contributing drainage area captured can be read. For example, if a 10 by 50 foot roof is to be treated, the total roof area is 10x50 = 500 square feet. This could be handled by one tank 30" high, 48" diameter. It can also be handled by two tanks 30" high, 30" in diameter.

Measure the site infiltration rate according to Appendix A, if it is less than 0.25 in/hr, a dry well is not suitable for your site. If it higher than 0.50 in/hr, the size of the dry well can be reduced. For every 0.5 in/hr increase in measured infiltration rate above 0.50 in/hr subtract ten percent of the required dry well size as measured in square feet captured.

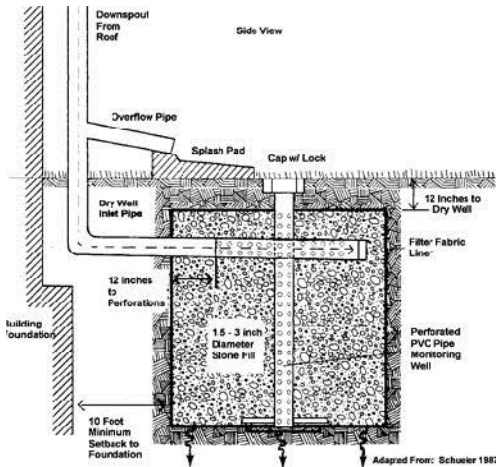

Gravel Bed Depth (inches)	Tank Height (inches)	Tank Inside Diameter (inches)					
		30	36	42	48	60	72
		Contributing Area Captured (square feet)					
6	30	290	380	480	590	840	1150
12	30	320	420	520	640	920	1240
6	60	-	-	-	-	1570	2140
12	60	-	-	-	-	1640	2240

Hole Depth (inches)	6" Perforated Standpipe Gravel Filled Hole Diameter (inches)						
	24	30	36	42	48	60	72
		Contributing Area Captured (square feet)					
24	30	50	60	80	100	160	230
30	-	60	80	100	130	200	280
36	-	-	90	120	150	240	340
42	-	-	-	140	180	280	390
48	-	-	-	-	200	310	450
60	-	-	-	-	-	390	560

## VEGETATION

- The landscaped area above the surface of a dry well should be covered with pea gravel if water enters the dry well through surface features rather than a pipe. This pea gravel layer provides sediment removal and additional pretreatment upstream of the dry well and can be easily removed and replaced when it becomes clogged.
- Alternatively, a dry well may be covered with an engineered soil mix, and planted with managed turf or other herbaceous vegetation.

## MAINTENANCE

Annual maintenance is important for dry wells to ensure they continue to provide measurable stormwater management benefits over time.

- Inspect gutters and downspouts removing accumulated leaves and debris.
- Inspect dry well following rainfall events.
- If applicable, inspect pretreatment devices for sediment accumulation. Remove accumulated trash and debris.
- Inspect top layer of filter fabric for sediment accumulation. Remove and replace if clogged.





### DRY WELLS

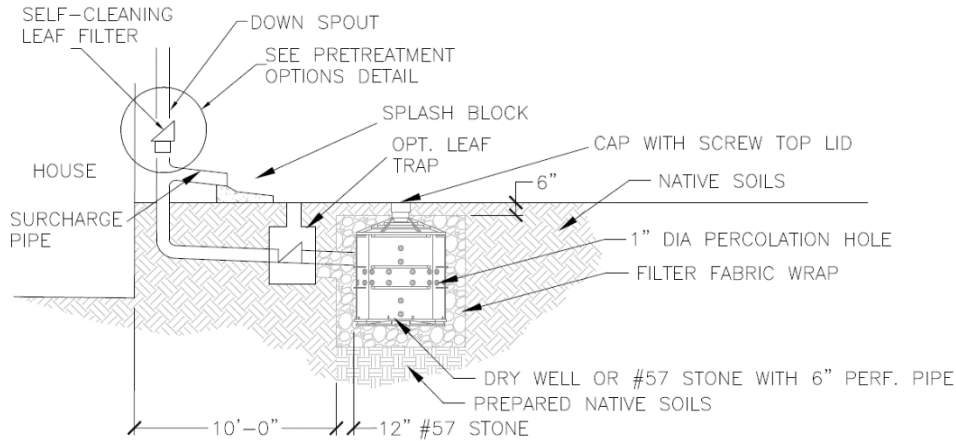

TYPICAL COMPONENTS (ATTACH MANUFACTURER'S SPECIFICATIONS)

**CONSTRUCTION STEPS:**

1. Review potential dry well areas and layout. Dry wells shall not be located: (1) beneath an impervious (paved) surface; (2) above an area with a water table or bedrock less than two feet below the trench bottom; (3) over other utility lines; or, (4) above a septic field. Ensure outlet daylight or is discharge through a popup emitter at least ten feet from property line.
2. Measure the area draining to the dry well and determine required size from the table on the next page.
3. Perform an infiltration test according to Appendix A. If the rate is less than 0.25 in/hr this method cannot be used. If the rate is more than 0.50 in/hr the storage volume may be decreased 10% for every 0.50 in/hr of infiltration rate increase above 0.50 in/hr.
4. Measure elevations and dig the hole to the required dimensions. Scarify the bottom soil surface 3-4 inches.
5. Place and tamp 6" to 12" of #57 gravel in bottom. Pea gravel can be substituted for leveling purposes in the upper three inch layer below the tank.
6. Place and secure filter cloth down sides of the excavation leaving enough to fold over the top below the soil and turf.
7. Place tank and install piping. Bond top of tank in place.
8. Cut and route downspouts or other rainwater delivery components; install chosen leaf screen option(s) (circle selected options in Pretreatment Options Detail figure). Strap and support as needed.
9. Create a safe overflow at least 10 feet from your property line and ensure it is protected from erosion.
10. Test connections with water flow.
11. Fill with gravel jacket around tank and place permeable fabric above between gravel and soil.
12. Backfill with soil/sod or pea gravel.
13. Consider aesthetics as appropriate and erosion control for overflow.

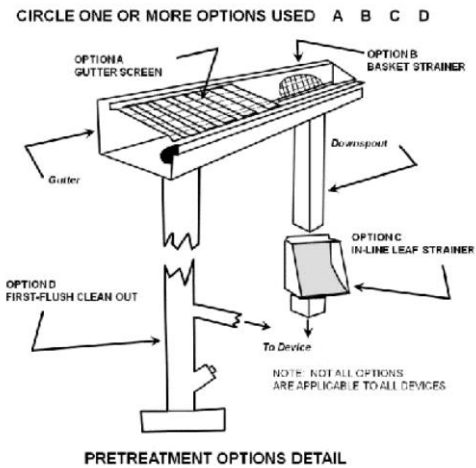

CITY OF KIRKWOOD	NAME/ADDRESS:	DRY WELL SPECIFICATIONS PAGE 1 OF 2
------------------	---------------	--



**DRY WELL – LAYOUT SKETCH**

PROVIDE PLAN AND ELEVATION VIEWS OF DRY WELL AND HOUSE SHOWING ROOF AREA DIRECTED TO DRY WELL AND KEY DIMENSIONS, CONNECTIONS AND OVERFLOW RELATIVE TO PROPERTY LINE.

**SIZING CALCULATION:**

SITE INFILTRATION RATE= \_\_\_\_\_ IN/HR

- IS BMP SUITABLE FOR SITE? YES NO
- CAN BMP SIZE BE REDUCED? YES NO

Gravel Bed Depth (inches)	Tank Height (inches)	Tank Inside Diameter (inches)					
		30	36	42	48	60	72
Contributing Area Captured (square feet)							
6	30	290	380	480	590	840	1150
12	30	320	420	520	640	920	1240
6	60	-	-	-	-	1570	2140
12	60	-	-	-	-	1640	2240

Hole Depth (inches)	6" Perforated Standpipe Gravel Filled Hole Diameter (inches)						
	24	30	36	42	48	60	72
Contributing Area Captured (square feet)							
24	30	50	60	80	100	160	230
30	-	60	80	100	130	200	280
36	-	-	90	120	150	240	340
42	-	-	-	140	180	280	390
48	-	-	-	-	200	310	450
60	-	-	-	-	-	390	560

MEASURE CONTRIBUTING DRAINAGE AREA AND READ AREA FOR GIVEN MEDIA DEPTH.

CONTRIBUTING DRAINAGE AREA= \_\_\_\_\_ SQ FT

TANK DIAMETER/WIDTH= \_\_\_\_\_ INCHES

TANK HEIGHT= \_\_\_\_\_ INCHES

GRAVEL BED DEPTH= \_\_\_\_\_ (6 OR 12 INCHES)

ALTERNATIVE STANDPIPE DESIGN

HOLE DIAMETER= \_\_\_\_\_ INCHES

HOLE DEPTH= \_\_\_\_\_ INCHES

**MAINTENANCE:**

1. INSPECT GUTTERS AND DOWNSPOUTS REMOVING ACCUMULATED LEAVES AND DEBRIS, CLEANING LEAF REMOVAL SYSTEM(S).
2. IF APPLICABLE, INSPECT PRETREATMENT DEVICES FOR SEDIMENT ACCUMULATION. REMOVE ACCUMULATED TRASH AND DEBRIS.
3. INSPECT DRY WELL FOLLOWING A LARGE RAINFALL EVENT TO ENSURE OVERFLOW IS OPERATING AND FLOW IS NOT CAUSING PROBLEMS.

CITY OF KIRKWOOD

ATTACH THIS TWO-PAGE  
SPECIFICATION TO HOUSE PLAN  
SUBMITTAL

DRY WELL SPECIFICATIONS  
PAGE 2 OF 2

## VEGETATED FILTER STRIP AREAS

\* AMENDED SOIL OR BERM OPTIONS ARE AVAILABLE IN THIS SECTION

A vegetated filter strip can be an attractive and functional addition to your home landscape. Vegetated filter strip areas (including amended soil) are uniformly graded, vegetated areas of land designed to receive rainwater as sheet flow and to slow and filter stormwater runoff from roof downspouts or parking areas. Vegetated filter strips can provide significant reductions in stormwater runoff and pollutant loads in your local watershed.



### LOCATION

- Observe the drainage patterns to determine the best location for a vegetated filter strip area. Assess the drainage area flow paths on your property, and the slope of the drainage area. Ideal locations are places where there is a gentle slope away from the structure or paved area, the area is relatively flat, and where the flow can be evenly distributed along the top of the filter area.
- The ideal slope of the vegetated filter strip area should be between 1% and 5%. Greater slopes would encourage the formation of concentrated flow within the filter strip area; lesser slopes would encourage unintended ponding. If the slope is greater, terracing can be used by installing level spreaders between each terrace.
- A filter strip area may be placed over utilities except when using the amended soil option. In that case, ensure utility locations are noted and care is taken to avoid them in soil amendment actions. NOTE: Amended or bermed filter strips should not be placed over a septic field.
- The length of the vegetated filter strip area should be no less than 25 feet. If there is a permeable berm at the lower end, the length of the vegetated filter strip area should be no less than 15 feet. Natural forested areas on site can be counted in the total length of the filter area.
- The area of impervious surface draining to any one discharge location cannot exceed 5,000 square feet.

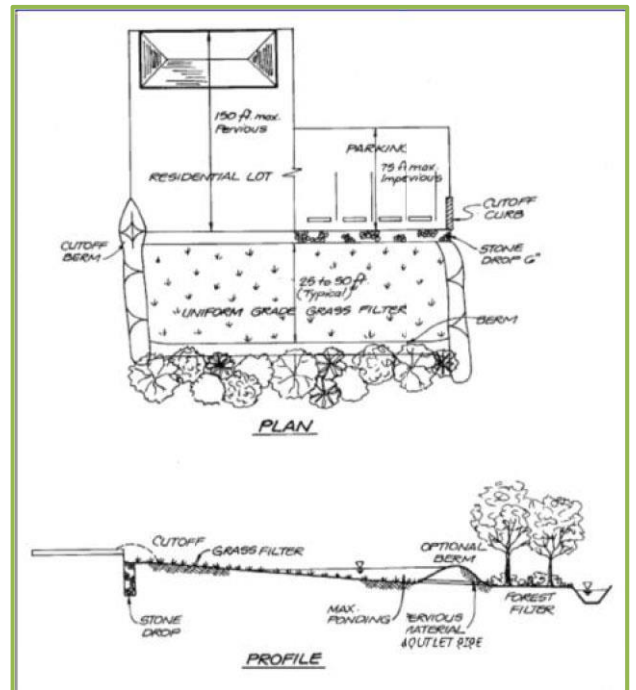

Source: Center for Watershed Protection. 2009.  
Coastal Stormwater Supplement to the Georgia  
Stormwater Management Manual.

### CONSTRUCTION

#### Level Spreader

- A level spreader must be used at the upstream end of the filter area to evenly distribute stormwater runoff. A level spreader is a small trench filled with pea gravel or ASTM No. 8 stone installed along a level contour.
- The level spreader should be 12" to 18" wide and 6" to 12" deep depending on the amount of expected flow. Larger diameter stone may be required to stabilize entry points for larger contributing impervious areas.
- To help ensure more even distribution of flow into the filter area, notches can be cut in the level spreader at intervals allowing overflowing water to enter at several locations ahead of general overflow.



- The level spreader can be connected to the downspout via a T-connection to the perforated pipes embedded in the level spreader trench (see figure).
- Ensure the overflow points are protected from erosion and not blocked by vegetation.
- If the impervious drainage area to any one entry point (e.g. a downspout) is less than 1,000 square feet appropriate level spreaders may be waived if flow will flow as a sheet through the strip area. In this case simple splash blocks (see figure) can be used to introduce flow into turf (yard) areas.

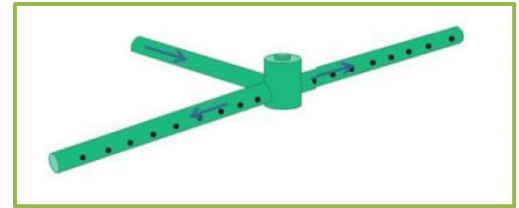

**Conventional Design Option**

- Conventional vegetated filter strip areas are uniformly graded BMP’s that use an area of densely planted vegetation (typically grass) and a flat cross slope to maintain sheet flow and promote infiltration.
- **NOTE: This method cannot be used if the results of the soil infiltration test described in Appendix A are less than 0.50 inch per hour; the amended soil design option must be used instead.**

**Berm Design Option**

- A greater ability to meet the 1.14 inch standard can be achieved through the use of a permeable berm at the bottom end of the filter strip. The permeable berm is used to temporarily store stormwater runoff within the filter area, which increases the infiltration and reduces the required width of the filter area.
- Permeable berms should be constructed of well-drained soils (sand, gravels, and sandy loams) that support plant growth, and should be no more than 12” high.
- Appropriately sized outlets should be provided within permeable berms to ensure that vegetated filter areas will drain within 24 hours following the end of a rainfall event.
- A stone-protected overflow area cut through the berm may be used to manage the stormwater runoff generated by large storm events. The overflow point must be at least ten feet from the property line if flow is directed onto an adjoining property. Erosion protection is critical.
- **NOTE: This method cannot be used if the results of the soil infiltration test described in Appendix A are less than 0.50 inch per hour; the amended soil design option must be used instead.**



Source: www.neorsd.org

**Amended Soil Design Option**

- Increased infiltration and a doubling of the ability to meet the 1.14 inch rain standard can be achieved by amending the soil within the filter area by tilling the existing soil to a depth of 12” and mixing in 4” of compost.
- **NOTE: The soil infiltration rate suitable for the Amended Soil Design Option is 0.25 in/hr or greater. If the results of the soil infiltration test described in Appendix A are less than 0.25 in/hr, provide an underdrain leading to daylight or discharged with a popup emitter as described in Appendix D.**

**Design Table**

Measure the rooftop and other areas to be directed to the filter strip area. Depending on the site layout select the size and type of filter strip area from the table at right to meet the 1.14-inch design standard. For example, for a 1,000 square foot rooftop, a conventional filter strip must have a surface area of at least 2,000 square feet and a minimum flow length of 25 feet. If built with a berm, it can have a surface area of 700 square feet and a minimum flow length of 15 feet.

Contributing Drainage Area (square feet)	Filter Strip Type		
	Conventional	Amended Soil	Berm
	Filter Strip Area (sq ft)		
100	200	100	75
500	1000	500	350
1000	2000	1000	700
2000	4000	2000	1500
3000	6000	3000	2000
4000	8000	4000	3000
5000	10000	5000	3500



---

## VEGETATION

---

- Vegetation commonly planted on vegetated filter strip area includes turf, shrubs, trees, and other herbaceous vegetation.
- Choose grasses and other vegetation that will be able to tolerate the stormwater runoff rates and volumes that will pass through the vegetated filter strip area.
- Vegetation used in filter strip areas should be able to tolerate both wet and dry conditions.
- Refer to Appendix B for more guidance.

---

## MAINTENANCE

---

Maintain the vegetated filter strip area so that it will continue to provide measurable stormwater management benefits over time.

- Water as needed to promote plant growth and survival especially in the first two seasons.
  - Provide normal turf or garden maintenance - mow, prune, and trim as needed.
  - Inspect the vegetated filter strip area following rainfall events. Correct erosion issues immediately.
  - Remove accumulated trash, sediment, and debris.
-



### VEGETATED FILTER STRIP AREAS TYPICAL COMPONENTS

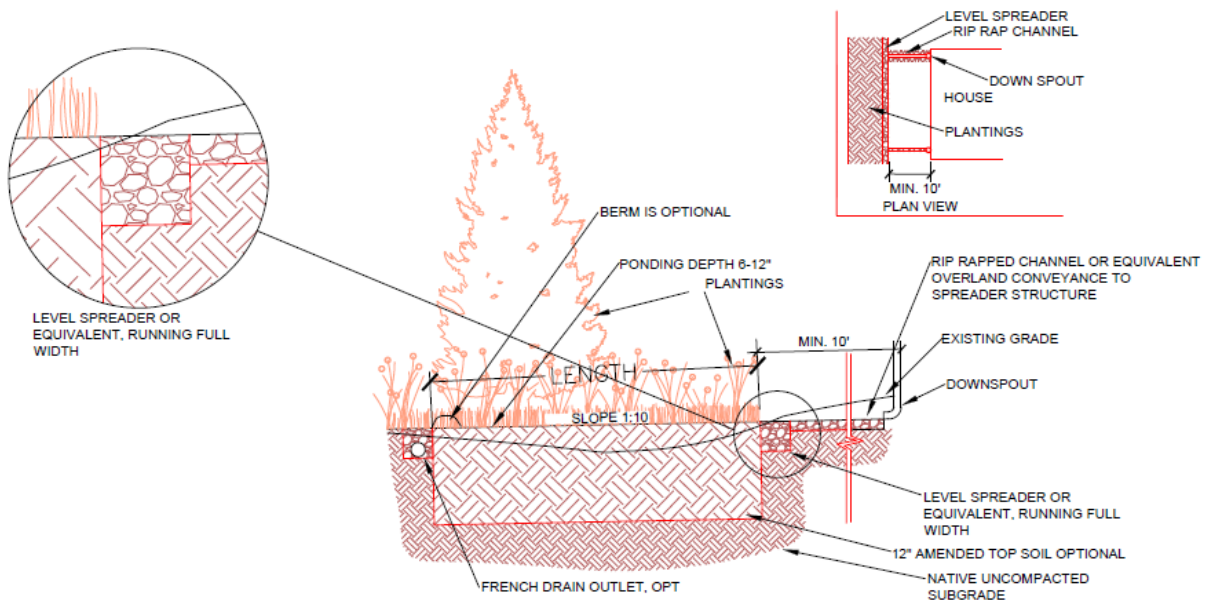

**CONSTRUCTION STEPS:**

1. Review potential filter strip areas and layout. Filter strips should slope between 1% and 5% away from the structure and should not be located above a septic field. Filter strips may be located over utilities except when using the amended soil option. In that case, be sure to note utility locations and take care when preparing the amended soil. If there is a concentrated overflow, ensure it is at least ten feet from adjacent property.
2. Perform an infiltration test according to Appendix A. If the rate is less than 0.25 in/hr the amended soil option must be used. If the infiltration rate is less than 0.05 in/hr, this method can only be used with an underdrain as described in Appendix D.
3. Measure the area draining to the filter strip and determine required surface area and minimum length from the table on the next page. Determine the desired filter strip and level spreader options.
4. Lay out and mark the filter strip area, flow spreader line, and inlets.
5. Construct level spreader by filling trench with appropriate gravel, taking note of overflow points.
6. Construct filter strip option, prepare soil.
7. Construct erosion control at the flow entrance and exit points as needed.
8. Plant dense vegetation according to plan, or sod/seed. Ensure an irrigation plan is in place.
9. Ensure temporary erosion control is in place as needed until vegetation is well-established.

CITY OF KIRKWOOD	NAME/ADDRESS:	FILTER STRIP SPECIFICATIONS PAGE 1 OF 2
------------------	---------------	--



**VEGETATED FILTER STRIP – LAYOUT SKETCH**

PROVIDE PLAN AND ELEVATION VIEWS OF FILTER STRIP AND STRUCTURE/HOUSE SHOWING ROOF AREA DIRECTED TO FILTER STRIP WITH KEY DIMENSIONS, CONNECTIONS AND OVERFLOW RELATIVE TO PROPERTY LINE.

**SIZING CALCULATION:**

SITE INFILTRATION RATE= \_\_\_\_\_ IN/HR

- WHICH OPTION SUITABLE FOR THE SITE? \_\_\_\_\_
- IS AN UNDERDRAIN REQUIRED? YES NO

Contributing Drainage Area (square feet)	Filter Strip Type		
	Conventional	Amended Soil	Berm
	Filter Strip Area (sq ft)		
100	200	100	75
500	1000	500	350
1000	2000	1000	700
2000	4000	2000	1500
3000	6000	3000	2000
4000	8000	4000	3000
5000	10000	5000	3500

MEASURE CONTRIBUTING DRAINAGE AREA AND READ AREA FOR GIVEN FILTER STRIP TYPE.

CONTRIBUTING DRAINAGE AREA= \_\_\_\_\_ SQ FT

FILTER STRIP AREA= \_\_\_\_\_ SQ FT

CONVENTIONAL – 25’ MINIMUM LENGTH

BERM OPTION – 15’ MINIMUM LENGTH

**MAINTENANCE:**

1. INSPECT GUTTERS AND DOWNSPOUTS, REMOVE ACCUMULATED LEAVES AND DEBRIS, CLEAN LEAF REMOVAL SYSTEM(S).
2. IF APPLICABLE, INSPECT PRETREATMENT DEVICES FOR SEDIMENT ACCUMULATION. REMOVE ACCUMULATED TRASH AND DEBRIS.
3. WATER AS NEEDED TO PROMOTE PLANT GROWTH AND SURVIVAL ESPECIALLY IN THE FIRST TWO SEASONS.
4. PROVIDE NORMAL TURF OR GARDEN MAINTENANCE - MOW, PRUNE, AND TRIM AS NEEDED.
5. INSPECT THE VEGETATED FILTER STRIP FOLLOWING RAINFALL EVENTS. CORRECT EROSION ISSUES IMMEDIATELY.

CITY OF KIRKWOOD

ATTACH THIS TWO-PAGE SPECIFICATION TO HOUSE PLAN SUBMITTAL

FILTER STRIP SPECIFICATIONS PAGE 2 OF 2



## MODIFIED FRENCH DRAINS

Modified French Drains (MFD) are shallow trench excavations filled with stone that are designed to intercept and temporarily store storm water runoff until it infiltrates into the soil. MFDs can provide significant reductions in storm water runoff and pollutant loads. They are particularly well suited to receive rooftop runoff, but can also be used to receive storm water runoff from other small impervious areas. In Kirkwood, only the daylighted French Drain version is permitted in residential applications. The perforated pipe is daylighted at its end to allow for overflow of larger storm events as a failsafe mechanism if infiltration is less than anticipated.



### LOCATION

- MFD trenches should be located at least 5 feet from building foundations and 10 feet from buildings with basements and property lines. The top end of the MFD can be adjacent to the building to connect downspouts but should be directed away from the structure.
- MFDs should slope away from the structures. The slope of the MFD pipe should be between 0.5% and 6%. It can be serpentine or multi-pronged in construction if sufficient slope is available.
- To reduce the chance of clogging, MFDs should drain only impervious areas. Pretreat runoff with at least one of the leaf removal options to remove particulates and larger debris.
- MFD gravel depths should be at least 18 inches and no more than 36 inches.
- MFDs should be located in a lawn or other pervious (unpaved) area; and should be designed so that the top of the MFD is located as close as possible to the soil surface to reduce digging.
- NOTE: MFDs should not be located: (1) beneath an impervious (paved) surface; (2) above an area with a water table or bedrock less than two feet below the trench bottom; (3) over other utility lines; or, (4) above a septic field. Always call Missouri One Call to locate utility lines before you dig.
- The downstream end of the pipe must daylight or be discharged with a pop-up emitter for overflows at least ten feet from the property line.

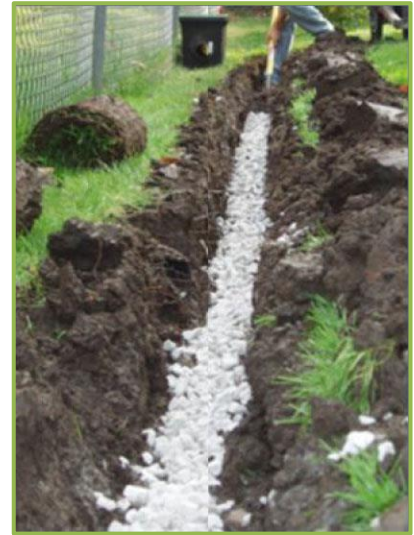

### CONSTRUCTION

- As a rule of thumb, there should be about 23 cubic feet of stone for every 100 square feet of rooftop. The table provides MFD length requirements for different depths.
- Measurements in the table at right are based on trench width of 24 inches, however the width can be from 18 to 32 inches. Required lengths should be adjusted proportionately if other widths are used.
- The sides of the excavation should be trimmed of all large roots that will hamper the installation of the permeable drainage fabric to be placed part way down the sides and above the gravel layer on top of the MFD.

Rooftop Area (square feet)	Depth of Gravel From Top of Pipe (inches)			
	18	24	30	36
	Required Linear Feet of MFD			
100	7	5	4	4
500	35	25	20	20
1000	70	55	45	35
2000	140	110	90	75
3000	210	160	130	110
4000	280	215	175	150
5000	345	270	220	185





- 
- Scarify or till the native soils along the bottom of the MFD to a depth of 3-4 inches.
  - Fill the MFD with clean, washed ASTM No. 57 stone; embed a six-inch diameter perforated pipe in the top top of the stone such that the stone covers the top of the pipe. No. 57 stone averages ½ inch to 1-½ inches.
  - The pipe should have 3/8 inch perforations, spaced 6 inches on center, and have a minimum slope of 0.5% and a maximum slope of 6%.
  - The perforated pipe must daylight at the downstream end of the trench.
  - An overflow, such as a vegetated filter strip area or grass channel, must be designed to safely convey stormwater runoff generated by larger storm events out of the downstream end of the MFD.
  - Place permeable landscape fabric over soil/pea gravel to prevent it from migrating into the stone. and clogging the pore spaces; leave a four to six inch space above the pipe to the ground surface.
  - Cover with top soil and sod or with pea gravel.
  - For rooftop runoff, install one or more leaf screen options upstream from/ahead of the MFD to prevent leaves and other large debris from clogging the MFD. For driveway or parking runoff a screened inlet grate over a sump or pea gravel pit can be used to settle out material prior to entering the pipe.
  - **NOTE: This method cannot be used if the results of the soil infiltration test described in Appendix A are less than 0.25 in/hr.**

---

## VEGETATION

- MFDs are normally covered with topsoil and managed turf or other herbaceous vegetation.
- As an alternative, the area above the surface of a MFD may be covered with pea gravel (or larger depending on the inflow rates) to allow for incidental lateral inflow along the edge of ground level impervious surfaces.
- The downstream end of the pipe must be stabilized and can be landscaped for aesthetics.

---

## MAINTENANCE

Annual maintenance is important for MFDs.

- Inspect gutters and downspouts removing accumulated leaves and debris, and cleaning leaf removal system(s).
  - Inspect any pretreatment devices for sediment accumulation. Remove accumulated trash and debris.
  - Inspect MFDs following a large rainfall event to ensure overflow is operating and flow is not causing problems.
-



**MODIFIED FRENCH DRAINS**

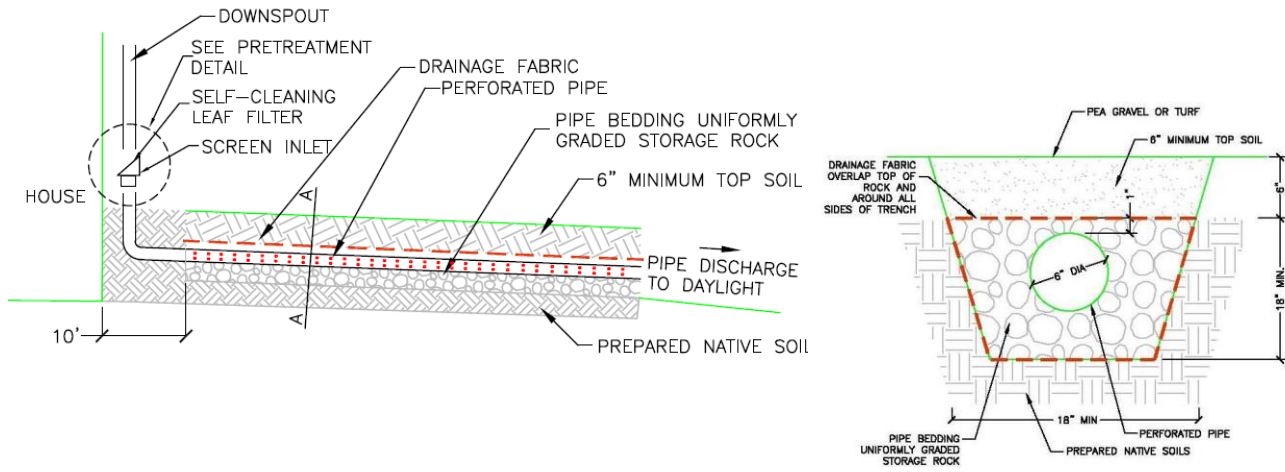

**SECTION A-A**

**CONSTRUCTION STEPS:**

1. Review potential MFD areas and layout. MFDs should slope between 0.5% and 6% away from structures and should not be located: (1) beneath an impervious (paved) surface; (2) above an area with a water table or bedrock less than two feet below the trench bottom; (3) over other utility lines; or, (4) above a septic field. Ensure outlet daylights or is discharged with a pop-up emitter at least ten feet from property line.
2. Measure the area draining to the MFD and determine required length from the table on the next page using assumed width and gravel depth, and plan route and excavation depth.
3. Perform an infiltration test according to Appendix A. If the rate is less than 0.25 in/hr, this method cannot be used. If the rate is more than 0.50 in/hr, the length of the ditch may be decreased 10% for every 0.50 in/hr infiltration rate increase above 0.50 in/hr.
4. Measure elevations and lay out the MFD to the required dimensions marking the route and required excavation depths. Often a level line (torpedo level) is used.
5. Remove sod using a sod cutter if appropriate. Excavate ditch to the depth of the gravel plus six inches for topsoil/pea gravel and three additional inches to accommodate half the pipe depth. Be careful not to compact soils in the bottom. Level the bottom laterally as much as possible to maximize the infiltration area. Roughen bottom to a depth of at least three inches and trim roots.
6. Place and tamp gravel in ditch to planned depth placing the pipe three inches deep in the upper portion of the gravel. Then place and gently tamp gravel until it covers the pipe.
7. Place drainage fabric over top of pipe and stone.
8. Place topsoil and sod or pea gravel.
9. Cut and route downspouts or other rainwater delivery components, leaf screen option(s) chosen (circle selected options in Pretreatment Options Detail figure). Strap and support as needed.
10. Create a safe overflow at least 10 feet from your property edge and ensure it is protected from erosion.

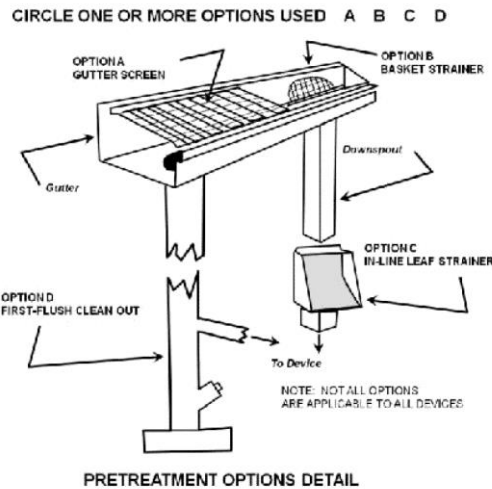

<p>CITY OF KIRKWOOD</p>	<p>NAME/ADDRESS:</p>	<p>MODIFIED FRENCH DRAIN SPECIFICATIONS PAGE 1 OF 2</p>
-------------------------	----------------------	---



**MODIFIED FRENCH DRAIN – LAYOUT SKETCH**

PROVIDE PLAN AND ELEVATION VIEWS OF MFD AND HOUSE SHOWING ROOF AREA DIRECTED TO MFD AND KEY DIMENSIONS, CONNECTIONS AND OVERFLOW RELATIVE TO PROPERTY LINE.

**SIZING CALCULATION:**

SITE INFILTRATION RATE= \_\_\_\_\_ IN/HR

- IS BMP SUITABLE FOR SITE? YES NO
- CAN BMP SIZE BE REDUCED? YES NO

Rooftop Area (square feet)	Depth of Gravel From Top of Pipe (inches)			
	18	24	30	36
	Required Linear Feet of MFD			
100	7	5	4	4
500	35	25	20	20
1000	70	55	45	35
2000	140	110	90	75
3000	210	160	130	110
4000	280	215	175	150
5000	345	270	220	185

MEASURE CONTRIBUTING DRAINAGE AREA AND READ AREA FOR GIVEN MEDIA DEPTH.

CONTRIBUTING DRAINAGE AREA= \_\_\_\_\_ SQ FT  
 DEPTH OF STONE MEDIA= \_\_\_\_\_ INCHES  
 WIDTH OF TRENCH= \_\_\_\_\_ INCHES  
 LENGTH OF MFD= \_\_\_\_\_ FT

**MAINTENANCE:**

1. INSPECT GUTTERS AND DOWNSPOUTS, REMOVE ACCUMULATED LEAVES AND DEBRIS, CLEAN LEAF REMOVAL SYSTEM(S).
2. IF APPLICABLE, INSPECT PRETREATMENT DEVICES FOR SEDIMENT ACCUMULATION. REMOVE ACCUMULATED TRASH AND DEBRIS.
3. INSPECT MFD FOLLOWING A LARGE RAINFALL EVENT TO ENSURE OVERFLOW IS OPERATING AND FLOW IS NOT CAUSING PROBLEMS.

CITY OF KIRKWOOD

ATTACH THIS TWO-PAGE  
SPECIFICATION TO HOUSE PLAN  
SUBMITTAL

MODIFIED FRENCH DRAIN  
SPECIFICATIONS  
PAGE 2 OF 2



## PERMEABLE PAVERS

Permeable pavers are an alternative to traditional paving surfaces which can decrease stormwater runoff around your home. They are well-suited for use when constructing sidewalks, parking areas, patios, and driveways. Permeable pavers consist of permeable interlocking or grid concrete pavers underlain by a drainage layer. A permeable paver system allows stormwater runoff to pass between the paver surfaces into an underlying stone reservoir, where it is temporarily stored and allowed to infiltrate into the underlying soil. Permeable pavers can provide significant reductions in stormwater runoff and pollutant loads in your watershed.

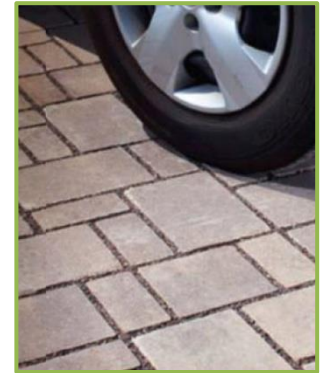

### LOCATION

- Maximum contributing drainage area ratio to surface area is 4:1.
- Permeable paver systems should be located at least 5 feet from building foundations and 10 feet from buildings with basements.
- NOTE: Permeable pavers should not be located: (1) above an area with a water table or bedrock less than two feet below the gravel bottom; (2) over other utility lines; or, (3) above a septic field. Always call Missouri One Call to locate utility lines before you dig.
- Permeable pavers should drain only impervious areas. Drainage from other areas onto the pavers will eventually clog them.
- Permeable paver systems should be installed on slopes less than 6% to help ensure even distribution of runoff over the infiltration surface; pavers should slope away from structures.

### CONSTRUCTION

The table at the right provides Permeable Paver area size requirements for different depths of the ASTM No. 57 stone layer. This stone averages in size from ½” to 1-½”. Example: A roof top measures 1000 square feet. For a stone depth of 8 inches the required area of permeable pavers 310 sq ft.

Contributing Drainage Area (square feet)	Depth of Lower Stone Storage Layer (inches)				
	4	5	6	8	12
	Area of Pavers (square feet)				
100	60	50	40	40	30
500	260	230	200	160	120
1000	520	450	390	310	230
2000	1040	890	780	620	450
3000	1550	1330	1170	930	670
4000	2070	1770	1550	1240	890
5000	2580	2220	1940	1550	1110

- Permeable paver systems require multiple layers. Manufacturer’s instructions, if available, should be followed in lieu of these guidelines.
- The top course consists of the pavers and a crushed aggregate material swept between the paver joints, such as ASTM No. 8 stone or 1/8” to 3/8” pea gravel. The thickness of this layer varies depending upon the depth of the paver.
- The bedding course consists of 2 to 3 inches of No. 8 stone, or 1/8” to 3/8” pea gravel. The bedding course provides a level bed for setting the pavers evenly.
- The aggregate base course consists of a minimum of 4 inches of No. 57 stone. The aggregate base course acts as a reservoir to provide stormwater storage capacity.
- A permeable drainage fabric must be used to separate the aggregate base course from the subgrade. This fabric must be a needle-punched nonwoven polypropylene geotextile with Grab Tensile Strength greater than or equal to 120 lbs (MSD Type 4 or equivalent).
- The subgrade layer is the layer of native soils below the gravel and the permeable drainage fabric. Prepare the subgrade soil layer by scarifying or tilling to a depth of 3-4 inches.
- Care should be taken to avoid compaction of the soil in the location planned for the permeable pavers

during home construction.

- Excavation to final subgrade elevation should not take place until the pavers are ready to be installed.
- Even though the permeable pavement surface is sloped, the sub-grade of the treatment measure should be flat and in some cases, terraced where the driveway has a steep slope, in order to promote infiltration, Additionally, this will prevent the stormwater from running along the bottom of the subgrade and discharging at the bottom of the slope.
- NOTE: The soil infiltration rate suitable for a paver system is 0.25 inches per hour (in/hr) or greater. Conduct a soil infiltration test per Appendix A, if the rate is less than 0.25 in/hr, provide an underdrain leading to daylight or discharged with a pop up emitter as described in Appendix D. Professional assistance shall be obtained in this case.

---

## MAINTENANCE

Maintenance is very important for permeable pavers systems, particularly in terms of ensuring that they continue to provide measurable stormwater management benefits over time.

- Remove accumulated sediment and debris from joint spaces monthly.
- Monitor the permeable paver system for excessive ponding during storm events and repair as needed.
- Vacuum, sweep, or blow permeable paver surfaces quarterly to keep the surface free of sediment.
- Sweep new No. 8 stone into the spaces between stones as needed. Inspect permeable paver surface for deterioration annually. Repair or replace any damaged areas as needed.

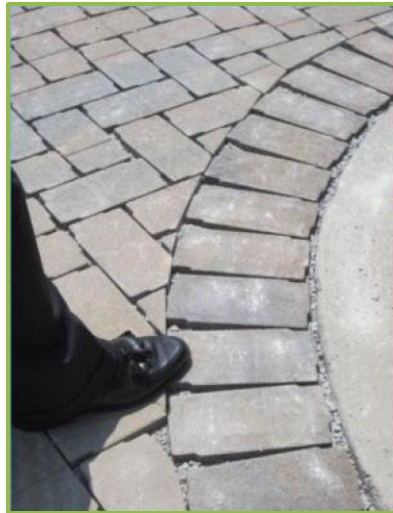



**PERMEABLE PAVERS – LAYOUT SKETCH**

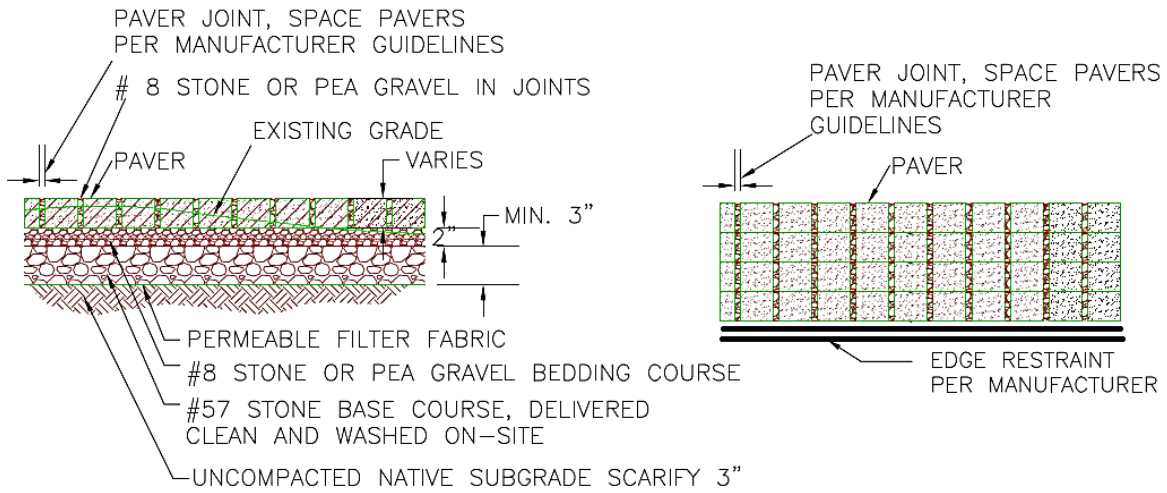

TYPICAL COMPONENTS (ATTACH MANUFACTURER'S SPECIFICATIONS)

**CONSTRUCTION STEPS:**

1. Review potential paver areas and layout. Pavers should slope less than 6% away from the structure and should not be located: (1) above an area with a water table or bedrock less than two feet below the trench bottom; (2) over other utility lines; or, (3) above a septic field.
2. Measure the area draining to the pavers and determine required paver area from the table on the next page based on the depth of the lower stone storage layer.
3. Perform an infiltration test according to Appendix A. If the rate is less than 0.25 in/hr this method can only be used with an underdrain as described in Appendix D. If the rate is more than 0.50 in/hr the paver area may be decreased 10% for every 0.50 in/hr of infiltration rate increase above 0.50 in/hr.
4. Excavate area to appropriate depth and scarify soil to 3-4 inches.
5. Place and tamp gravel to planned depth in no more than 6" lifts. Three-inch minimum depth.
6. Place and tamp No. 8 stone or pea gravel bedding layer. Two-inch minimum depth.
7. Lay paving stone one at a time or using mechanical placement as applicable. Cut stone at edges to fit.
8. Install edge restraints per manufacturer's specifications.
9. Sweep more No. 8 stone or pea gravel into stone joints until filled and even.
10. Cut and route downspouts or other rainwater delivery components, leaf screen option(s) chosen (circle selected options in Pretreatment Options Detail figure). Strap and support as needed.

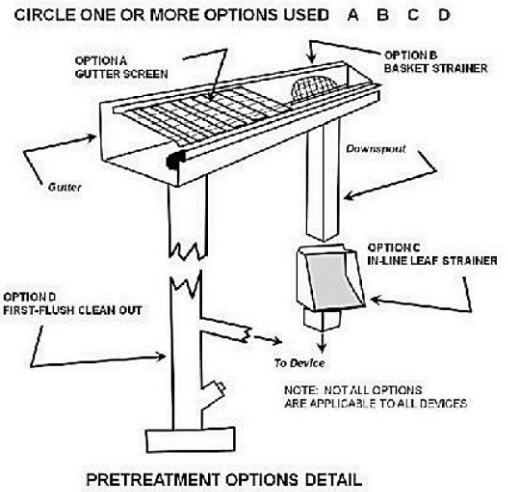

<p>CITY OF KIRKWOOD</p>	<p>NAME/ADDRESS:</p>	<p>PERMEABLE PAVER SPECIFICATIONS PAGE 1 OF 2</p>
-------------------------	----------------------	---



**PERMEABLE PAVERS – LAYOUT SKETCH**

PROVIDE PLAN AND ELEVATION VIEWS OF PERMEABLE PAVER SYSTEM AND STRUCTURES/HOUSE SHOWING ROOF AREA DIRECTED TO PAVERS AND KEY DIMENSIONS, CONNECTIONS AND ANY APPLICABLE OVERFLOW RELATIVE TO PROPERTY LINE. ATTACH MANUFACTURER’S SPECIFICATIONS IF APPLICABLE.

**SIZING CALCULATION:**

SITE INFILTRATION RATE= \_\_\_\_\_ IN/HR

- IS UNDERDRAIN REQUIRED? YES NO N/A
- CAN BMP SIZE BE REDUCED? YES NO N/A

Contributing Drainage Area (square feet)	Depth of Lower Stone Storage Layer (inches)				
	4	5	6	8	12
	Area of Pavers (square feet)				
100	60	50	40	40	30
500	260	230	200	160	120
1000	520	450	390	310	230
2000	1040	890	780	620	450
3000	1550	1330	1170	930	670
4000	2070	1770	1550	1240	890
5000	2580	2220	1940	1550	1110

MEASURE CONTRIBUTING DRAINAGE AREA AND READ AREA FOR GIVEN MEDIA DEPTH.

CONTRIBUTING DRAINAGE AREA= \_\_\_\_\_ SQ FT

DEPTH OF STONE MEDIA= \_\_\_\_\_ INCHES

PAVER AREA= \_\_\_\_\_ SQ FT

**MAINTENANCE:**

1. REMOVE ACCUMULATED SEDIMENT AND DEBRIS FROM JOINT SPACE MONTHLY.
2. MONITOR THE PERMEABLE PAVER SYSTEM FOR EXCESSIVE PONDING DURING STORM EVENTS AND REPAIR AS NEEDED.
3. VACUUM, SWEEP, OR BLOW PERMEABLE PAVER SURFACE QUARTERLY TO KEEP THE SURFACE FREE OF SEDIMENT. SWEEP NEW STONE INTO THE JOINTS AS NEEDED.
4. INSPECT PERMEABLE PAVER SURFACE FOR DETERIORATION ANNUALLY. REPAIR OR REPLACE ANY DAMAGED AREAS AS NEEDED.

CITY OF KIRKWOOD

ATTACH THIS TWO-PAGE SPECIFICATION TO HOUSE PLAN SUBMITTAL

PERMEABLE PAVER SPECIFICATIONS PAGE 2 OF 2



## RAIN GARDENS

Rain gardens are small, landscaped depressions that are filled with a mix of native soil and compost, and are planted with trees, shrubs and other garden-like vegetation. They are designed to temporarily store storm water runoff from rooftops, driveways, patios and other areas around your home while reducing runoff rates and pollutant loads in your local watershed. A rain garden can be a beautiful and functional addition to your landscape.



### LOCATION

- Rain gardens should be located to receive the maximum amount of storm water runoff from impervious surfaces, and where downspouts or driveway runoff can enter garden flowing away from the home.
- Swales, berms, or downspout extensions may be helpful to route runoff to the rain garden.
- Locate at least 10 feet from foundations, not within the public right of way, away from utility lines, not over septic fields, and not near a steep bluff edge. Call Missouri One Call before you dig to locate the utility lines on your property.
- Rain gardens on steep slopes (>10%) may require an alternative design with terracing.

### DESIGN

- The size of the rain garden will vary depending on the impervious surface draining to it and the depth of the amended soils. Use the table to determine the required surface area.
- A maximum ponding depth of 6 inches is allowed within rain gardens. On average, rain gardens drain within a day which will not create a mosquito problem.
- Design the rain garden entrance to immediately intercept inflow and reduce its velocity with stones, dense hardy vegetation or by other means.
- If sides are to be mowed, rain gardens should be designed with side slopes of 3:1(H:V) or flatter.
- For best results, it is suggested to test your soil characteristics as you would for a garden, or contact your local County Extension Service for help ([extension.missouri.edu/stlouis](http://extension.missouri.edu/stlouis)).
- Soils for rain gardens should be amended native soils containing: 2/3 native soils and 1/3 compost.
- A mulch layer consisting of 2-3 inches of non-floatable organic mulch (fine shredded hardwood mulch, pine straw, or leaf compost) should be included on the surface of the rain garden. Pine bark and wood chips should not be used.
- Often rain gardens have a better appearance and can be more easily maintained if they have defined edges similar to a normal garden.
- The overflow from the rain garden should be non-eroding and can consist of a small berm or even an inlet grate set at the proper elevation in the garden. The grate should be set at a slant or be domed to allow clogging debris to fall off.

Contributing Drainage Area (square feet)	Depth of Amended Soil (inches)			
	18	24	30	36
	Area of Rain Garden (square feet)			
100	7.7	6.7	6.0	5.3
500	40	35	30	28
1000	80	70	60	55
2000	155	135	120	110
3000	235	205	180	160
4000	310	270	240	215
5000	390	340	300	270



- **NOTE: This method can only be used with an infiltration rate greater than 0.25 in/hr. If the rate is less than 0.25 in/hr, this method can only be used with an underdrain as described in Appendix D.**

---

## VEGETATION

---

- Vegetation commonly planted in rain gardens includes native trees, shrubs and other herbaceous vegetation. When developing a landscaping plan, you should choose vegetation that will be able to stabilize soils and tolerate the storm water runoff rates and volumes that will pass through the rain garden.
- Vegetation used in rain gardens should also be able to tolerate both wet and dry conditions. Please refer elsewhere within this document for additional information on plants appropriate for rain gardens.
- As with any garden, in the first season the vegetation may require irrigation to become well established.
- It may be appropriate to plant more densely than a normal garden to obtain the benefit of plant soil stabilization and evapotranspiration as soon as possible.

---

## MAINTAIN

---

Routine garden maintenance should include weeding, deadheading, replacing dead plants, and replenishing mulch when depleted. Catching areas of erosion is also important as is correcting standing water problems. If standing water persists it may be necessary to place a perforated underdrain in the garden daylighting downstream.

---





**RAIN GARDEN – LAYOUT SKETCH**

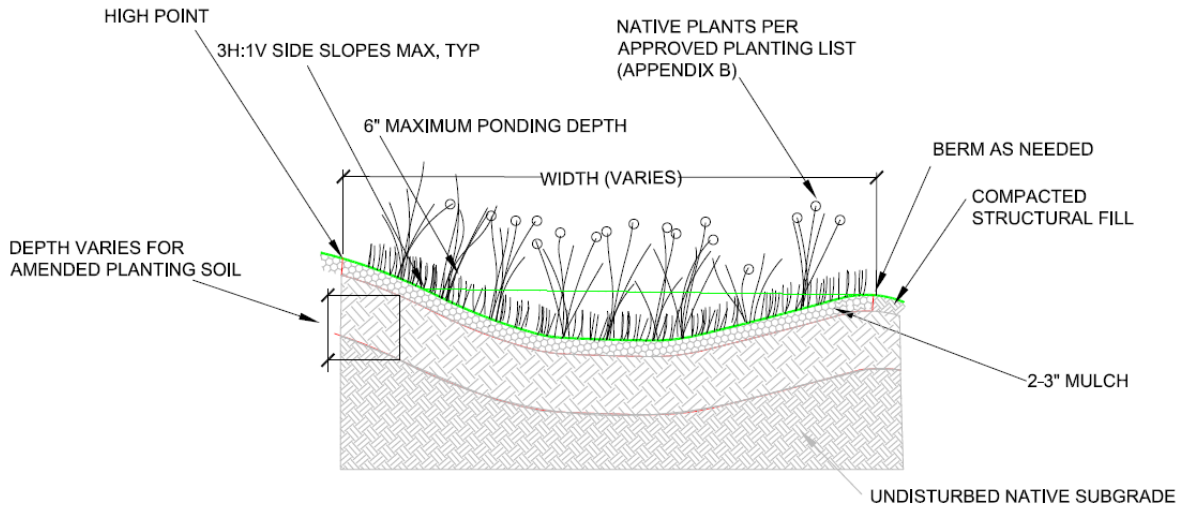

**CONSTRUCTION STEPS:**

1. Locate rain garden(s) where downspouts or driveway runoff can enter garden flowing away from the home. Locate at least 10 feet from foundations, not within the public right of way, away from utility lines, not over septic fields, and not near a steep bluff edge.
2. Measure the area draining to the planned garden and determine required rain garden surface area from the table on the next page and your planned excavation depth.
3. Perform an infiltration test according to Appendix A, if the rate is less than 0.25 in/hr an underdrain will be necessary. If the rate is more than 0.50 in/hr the size of the garden may be decreased 10% for every 0.50 in/hr infiltration rate increase above 0.50 in/hr.
4. Measure elevations and stake out the garden to the required dimensions insuring positive flow into the garden, the overflow elevation allows for six inches of ponding, and the perimeter of the garden is higher than the overflow point. If the garden is on a gentle slope a berm at least two feet wide can be constructed on the downhill side and/or the garden can be dug into the hillside taking greater care for erosion control at the garden inlet(s).
5. Remove turf or other vegetation in the area of the rain garden. Excavate garden being careful not to compact soils in the bottom of the garden. Level bottom of garden as much as possible to maximize infiltration area.
6. Mix compost, topsoil, and some of the excavated subsoil together to make the 'amended soil'. The soil mix should be 1/3 compost, 2/3 native soil (topsoil and subsoil combined).
7. Fill rain garden with the amended soil, leaving the surface eight inches below your highest surrounding surface. Eight inches allows for 6 inches ponding and 2" of mulch. The surface of the rain garden should be as close to level as possible.
8. Build a berm at the downhill edge and sides of the rain garden with the remaining subsoil. The top of the berm needs to be level, and set at the maximum ponding elevation.
9. Plant the rain garden using a selection of plants from elsewhere in this manual.
10. Mulch the surface of the rain garden with two to three inches of non-floating organic mulch. The best choice is finely shredded hardwood mulch.
11. Water all plants thoroughly. As in any new garden or flower bed, regular watering will likely be needed to establish plants during the first growing season.
12. During construction build the inlet feature as a pipe directly connected to a downspout or use a rock lined swale with a gentle slope. Use of an impermeable liner under the rocks at the end of the swale near the house is recommended to keep water from soaking in at that point. Test the drainage of water from the source to the garden prior to finishing.
13. Create an overflow at least 10 feet from your property edge and ensure it is protected from erosion.

CITY OF KIRKWOOD	NAME/ADDRESS:	RAIN GARDEN SPECIFICATIONS PAGE 1 OF 2
------------------	---------------	---



SKETCH LAYOUT

PROVIDE PLAN VIEWS OF RAIN GARDEN AND HOUSE SHOWING DRAINAGE AREA DIRECTED TO RAIN GARDEN AND KEY DIMENSIONS AND OVERFLOW AREA RELATIVE TO PROPERTY LINE.

SIZING CALCULATION:

SITE INFILTRATION RATE= \_\_\_\_\_ IN/HR

- IS UNDERDRAIN REQUIRED? YES NO N/A
- CAN BMP SIZE BE REDUCED? YES NO N/A

Contributing Drainage Area (square feet)	Depth of Amended Soil (inches)			
	18	24	30	36
	Area of Rain Garden (square feet)			
100	7.7	6.7	6.0	5.3
500	40	35	30	28
1000	80	70	60	55
2000	155	135	120	110
3000	235	205	180	160
4000	310	270	240	215
5000	390	340	300	270

MEASURE CONTRIBUTING DRAINAGE AREA AND READ AREA FOR GIVEN MEDIA DEPTH.

CONTRIBUTING DRAINAGE AREA= \_\_\_\_\_ SQ FT

DEPTH OF STONE MEDIA= \_\_\_\_\_ INCHES

PAVER AREA= \_\_\_\_\_ SQ FT

MAINTENANCE:

1. IRRIGATE VEGETATION AS NEEDED IN FIRST SEASON
2. REMOVE WEEDS
3. REPLACE UNSUCCESSFUL PLANTINGS
4. REPLENISH MULCH
5. REPAIR ERODED AREAS
6. RAKE CLOGGED SURFACE TO RESTORE INFILTRATION
7. MONITOR RAIN GARDEN FOR APPROPRIATE DRAINAGE TIMES. IF GARDEN DOES NOT DRAIN, AN UNDERDRAIN MAY BE NECESSARY

CITY OF KIRKWOOD

ATTACH THIS TWO-PAGE SPECIFICATION TO HOUSE PLAN SUBMITTAL

RAIN GARDEN SPECIFICATIONS PAGE 2 OF 2

## CREDIT FOR EXISTING TREES

Trees located on a residential lot can provide some benefit to storm water runoff reduction and can be used for credit in reducing the total net impervious area on a residential infill sites. Trees reduce runoff through rainfall interception by the tree canopy, by releasing water into the atmosphere through evapotranspiration, and by promoting infiltration and storage of water in the soil.

### CRITERIA

Each tree with an adjusted Diameter Breast Height (DBH) of 8 inches or greater can reduce the impervious area by 50 square feet if certain conditions are met:

- No more than 20% of the net added impervious area (IA) can be mitigated with the credit.
- The location, species, and size of each tree being counted for credit is shown on the plan of record. A picture of the tree should be included with the application.
- The tree is protected during construction.
- Bradford Pears and Ash trees will not be counted for credit.
- With the exception of the Vegetated Filter Strip Green Infrastructure Control, trees that are located within the boundaries of the constructed stormwater infrastructure features cannot be counted for Infill Stormwater Credit.

If the protected tree(s) dies or is removed, the property owner may be subject to enforcement and will be responsible for providing impervious area treatment. This may include planting and maintaining additional trees or installing Green Infrastructure Controls.

### MEASURING DBH

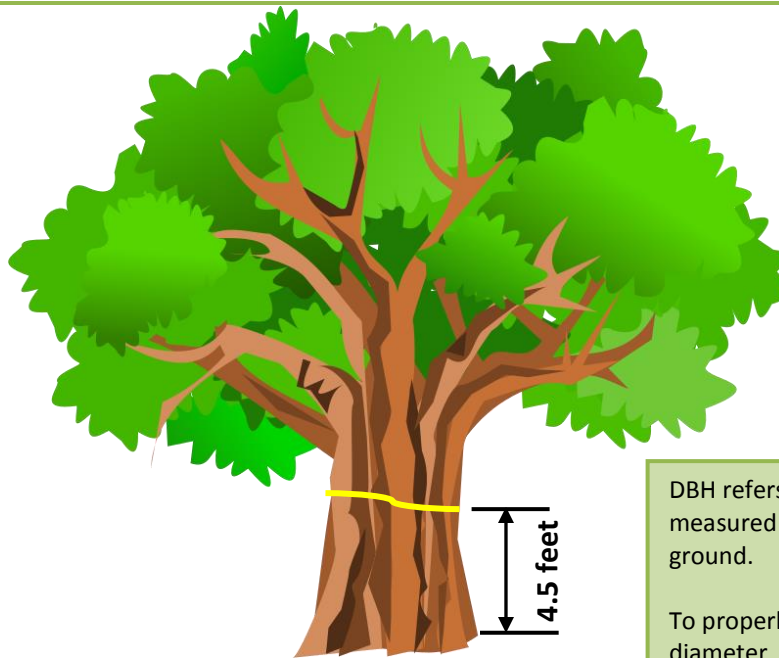

Figure 1: Measuring DBH

DBH refers to the tree diameter measured at 4.5 feet above the ground.

To properly determine the diameter, measure the length around the trunk and divide by 3.14.



---

## ADJUSTED DIAMETER

---

To calculate the tree's Adjusted Diameter, the DBH is multiplied by the tree's condition rating.

- The Condition Rating is the numerical expression of a tree's condition expressed as a percentage from zero (a dead tree) to 100 (a perfectly healthy tree as described in the manual Guide for Plant Appraisal published by the International Society of Arboriculture).
  - For example, if a tree has a DBH of 32 inches in diameter and is in relatively poor health with a condition rating of 40%, its adjusted diameter is 12.8 inches. ( $32'' \times 0.40 = 12.8''$ )
-



EXISTING TREES – LAYOUT SKETCH		
PROVIDE PLAN VIEW OF TREE LOCATIONS AND HOUSE SHOWING DRAINAGE AREA DIRECTED TO THE LOCATION.		
<p>TOTAL AREA ALLOWABLE AREA TO BE MITIGATED:</p> <p>DIFFERENTIAL IA ON SITE: _____ SQ FT</p> <p>MAX. ALLOWABLE IA = (DIFFERENTIAL IA) X 20% = _____ SQ FT</p> <p>DBH CALCULATION:</p> <p>MEASURE CIRCUMFERENCE OF TREE 4.5 FEET ABOVE THE GROUND.</p> <p>CIRCUMFERENCE = _____ INCHES</p> $DBH = \frac{CIRCUMFERENCE}{3.14}$ <p>DBH = _____ INCHES</p> <p>CONDITION RATING = _____%</p> $ADJUSTED\ DBH = CONDITION\ RATING \times DBH$ <p>ADJUSTED DBH= _____</p> <p>TREE SPECIES: _____</p> <p>TREE IA = 50 SQ FT X _____ TREES = _____ SQ FT</p> <p>IS AREA MITIGATED WITH TREES LESS THAN OR EQUAL TO THE MAXIMUM IA ALLOWABLE TO BE MITIGATED BY THE TREES? YES NO</p>	<p>MAINTENANCE:</p> <ol style="list-style-type: none"> <li>1. MULCH TREE WITH A 2-4 INCH LAYER OF MULCH IN A DOUGHNUT-SHAPED RING. THE RING SHOULD EXTEND 2' TO 4' BEYOND THE TRUNK.</li> <li>2. DO NOT PILE MULCH AGAINST THE TREE TRUNK. PULL MULCH BACK SEVERAL INCHES FROM THE TRUNK SO THE BASE OF THE ROOT CROWN IS EXPOSED. AVOID A "MULCH VOLCANO".</li> <li>3. AVOID OVER-PRUNING OF TREE BY ONLY REMOVING A SMALL PERCENTAGE OF THE LIVE TREE AT ONE TIME TO A MAX OF 25% IN ONE YEAR.</li> <li>4. HEAVY PRUNING SHOULD BE PERFORMED IN THE WINTER MONTHS.</li> <li>5. AVOID LIGHT PRUNING IN EARLY SPRING.</li> </ol>	
CITY OF KIRKWOOD	ATTACH THIS SHEET TO HOUSE PLAN SUBMITTAL	TREE INCENTIVE SPECIFICATIONS PAGE 1 OF 1

## APPENDIX A

### Site Infiltration Rate

Should you choose not to perform infiltration testing, your site infiltration rate will be 0.05 in/hr which excludes some BMP's as being applicable and others will require an underdrain. See Appendix D for details on constructing an underdrain.

### Testing Infiltration: the Simple Approach

It is assumed that an infiltration rate of 0.05 to 0.25 inches per hour exists on residential sites. The sizing criteria are set for this rate. However, if the soils have a higher infiltration rate the size of the features could be reduced.

If the following infiltration test is conducted, and if it returns a higher infiltration rate than 0.25 inches per hour, suitable reductions in the size of the infiltration-based facilities can be made. Any allowable reduction in BMP size requires that the infiltration test results be verified by a PE, geologist, or sanitarian. See each BMP for the adjustment procedure.

1. Infiltration features (rain gardens, dry wells, permeable paver gravel layers) should reliably drain within the recommended time limit. Here is how to test if your soils can handle this type of feature.
2. Locate the approximate center of the area where you expect to build your feature.
3. Dig an access pit down to the bottom of the amended soils or gravel layer in the feature.
4. At that elevation dig a narrow test hole at least eight inches deep. You can optionally place 2" of coarse gravel in the bottom. The test hole can be excavated with small excavation equipment or by hand using a spade shovel or post-hole digger.
5. If you run into a hard layer that cannot be penetrated with a shovel or, you come across water in the hole, stop. Infiltration features should not be sited over impenetrable rock surfaces or over high water tables. If this occurs, your site is inappropriate for these improvement measures.
6. Place a flat board across the hole to serve as a measuring point (see figure).
7. Fill the hole with water to a depth of twelve inches. Measure from the flat board to the water surface. Record the exact time you stop filling the hole and the height of the water every 10 minutes for fast draining soils for a minimum of one hour, or every 30 minutes for slow draining soils for a minimum of two hours. Most sites within the City limits will fall under the slow draining soils category. If the soil on your site appears sandy, it will be categorized as fast draining.
8. Refill the hole again and repeat step 7 twice more. The third test will give you the best measure of how quickly your soil absorbs water when it is fully saturated.
9. If on the third test the water is dropping at least ½" per hour the soil will work for the infiltration features.

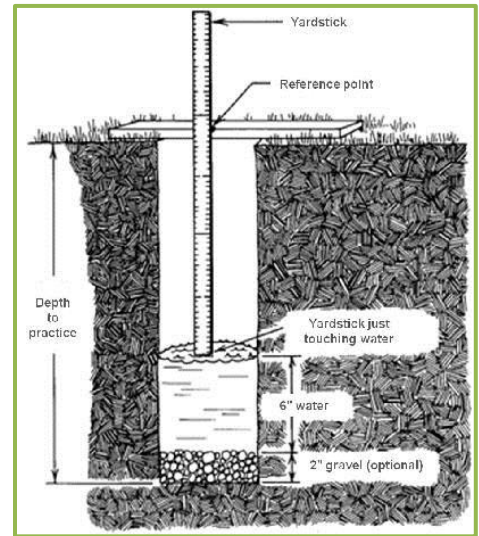

Source: modified from [www.ag.ndsu](http://www.ag.ndsu)



Source: [www.learntogrow.com](http://www.learntogrow.com)



**INFILTRATION TESTING CHECKLIST  
(IF REQUIRED)**

Project Information:

Date of Test: \_\_\_\_\_ Time of Test: \_\_\_\_\_

This Infiltration Test Was Performed by:  Homeowner  Other (specify below)

Company Name: \_\_\_\_\_ Contact Name: \_\_\_\_\_

Phone Number: \_\_\_\_\_ Email Address: \_\_\_\_\_

The intent of this checklist is to provide a summary of stormwater Best Management Practices (BMP) subsurface investigation and infiltration requirements. All projects and associated plans are also subject to the minimum requirements outlined this guideline. This checklist does not preclude the use of professional judgment to evaluate and manage risk associated with design, construction, and operation of infiltration BMPs.

**Part I. SUBSURFACE INVESTIGATION**

1. Dig a hole using a post hole digger to a depth of 2-ft below proposed facility and approximately 5-ft from the proposed infiltration facility.
2. Record total depth of hole from surrounding ground surface: \_\_\_\_\_ ft
3. While digging the hole, did you:
  - a. Encounter rock larger than gravel? YES NO
  - b. Encounter standing water or seepage into the hole? YES NO
4. If you answered "yes" to either 3a or 3b, the infiltration is not feasible for this site. **No further testing is required. Stop Here.**

**Part 2. INFILTRATION TEST**

1. Is the infiltration test within the footprint of the proposed infiltration facility? YES NO
2. If "no," is testing being conducted within 50 feet of the proposed infiltration facility? YES NO  
Explain why: \_\_\_\_\_
3.  Dig an infiltration test hole to the bottom of the BMP.
4. Describe soil type and texture (e.g., sand, clay, gravel.): \_\_\_\_\_
5.  Place a flat board across the hole to serve as a measuring point.
6.  Fill the hole with water to a depth of six inches. Measure from the flat board to the water surface. Record the exact time you stop filling the hole and height of the water every 10 minutes for fast draining soils for a minimum of one hour or every 30 minutes for slow draining soil for a minimum of 2 hours.
7.  Repeat step 6 two more times. The third test will govern. Record results in the appropriate tables, below.

**Table 1 (10-minute intervals)**

Time	Depth of water (in)	Difference in Water Depth (in)	Infiltration Rate (in/hr)	Depth of water (in)	Difference in Water Depth (in)	Infiltration Rate (in/hr)	Depth of water (in)	Difference in Water Depth (in)	Infiltration Rate (in/hr)
10		---	---		---	---		---	---
20									
30									
40									
50									
60									

The Difference in Water Depth is the difference between the depths of the current time minus the depth of the previous time. (i.e. 60 minute depth – 30 minutes depth)

CITY OF KIRKWOOD	NAME/ADDRESS:	INFILTRATION TESTING PAGE 1 OF 2





Table 1 (30-minute intervals)									
Time	Depth of water (in)	Difference in Water Depth (in)	Infiltration Rate (in/hr)	Depth of water (in)	Difference in Water Depth (in)	Infiltration Rate (in/hr)	Depth of water (in)	Difference in Water Depth (in)	Infiltration Rate (in/hr)
30		---	---		---	---		---	---
60									
90									
120									

The Difference in Water Depth is the difference between the depths of the current time minus the depth of the previous time. (i.e. 60 minute depth – 30 minutes depth)

8. Record the lowest infiltration rate from the tables above = \_\_\_\_\_ in/hr

$$\text{(Infiltration rate} = \frac{\text{difference in water depth (in)}}{\text{time (min)}} \times \frac{60 \text{ min}}{\text{hr}} = \text{in/hr)}$$

**SIGNATURES ARE REQUIRED**

I certify that I followed the procedures outlined in this document to determine the site infiltration rate.

Print Name: \_\_\_\_\_

Signature: \_\_\_\_\_ Date: \_\_\_\_\_

CITY OF KIRKWOOD	ATTACH THIS TWO-PAGE SPECIFICATION TO HOUSE PLAN SUBMITTAL	INFILTRATION TESTING PAGE 2 OF 2
------------------	--	----------------------------------

## APPENDIX B

### RECOMMENDED PLANTS – RAIN GARDENS

Recommended Plants for rain gardens and other vegetated storm water practices must be able to tolerate both wet and dry conditions. This list, while not exhaustive, includes many plants that will tolerate conditions in rain gardens. The plants in this list do have different preferences for both moisture and light, as shown in the columns labeled 'Moisture' and 'Sun'. Additionally, these plants are native to Missouri and thus contribute the added benefit of providing habitat and food for native pollinators and wildlife. Native plant species are preferred over non-native species, but some ornamental species may be used for a landscaping effect if they are not aggressive or invasive.



### PLANT SPACING

**Figure 1.** Typical plant spacing where x equals distance on center (O.C.) of plant species.

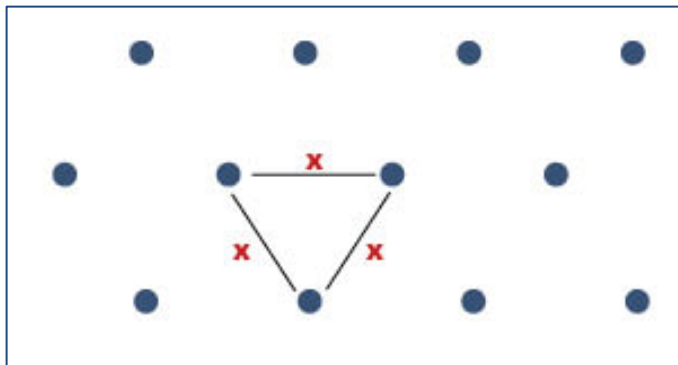

**Table 1.** is for use only when plants are spaced equidistant from each other as shown in **Figure 1**.

Table 1. Plant Spacing for Perennials, Grasses, Sedges and Shrubs	
Spacing (O.C.)	Plants per 100 sq.ft.
18" o.c.	51.2
24" o.c.	29
28" o.c.	22
30" o.c.	18.5
36" o.c.	12.8
42" o.c.	10
4' o.c.	7.23
5' o.c.	4.61
6' o.c.	3.2
8' o.c.	1.8



## PLANT LISTS

Plant material size and grade to conform to “American Standards for Nursery Stock” American Association of Nurserymen, Inc. latest approved revision, ANSI Z-60-1. The plants listings below are not exhaustive of all plants that will thrive in a rain garden or other vegetated storm water practices, and are only meant as a guide.

- Perennials and grasses/sedges should be planted with plugs or 1 gallon containers or equivalent, seed is not allowed. While it is less expensive to plant areas with seed, it is much more difficult and it takes about three years for most seedlings to mature and flower.
- Shrubs should be planted with 3 gallon containers or equivalent.
- Trees should be minimum 2” caliper.

**Table 2 : Native Perennials– Full Sun**

Latin Name	Common Name	Spacing	Moisture	Color	Height
<i>Amsonia illustris</i>	Shining Blue Star	24” o.c.	Wet-Moist	White/Blue	3-4’
<i>Asclepias incarnata</i>	Swamp / Marsh Milkweed	24” o.c.	Wet	Pink	3-4’
<i>Asclepias tuberosa</i>	Butterfly Milkweed	18” o.c.	Dry-moist	Orange	2’
<i>Asclepias verticillata</i>	Whorled Milkweed	18” o.c.	Moist	White	2.5’
<i>Asclepias vertis</i>	Green Milkweed	18” o.c.	Moist	Green	2’
<i>Aster novae-angliae</i>	New England Aster	24” o.c.	Moist-wet	Violet	3-4’
<i>Baptisia australis</i>	Blue False Indigo	24” o.c.	Moist-Dry	Blue	3-4’
<i>Baptisia bracteata</i>	Cream Wild Indigo	18” o.c.	Dry	Yellow	1-2’
<i>Baptisia sphaerocarpa</i>	Yellow Wild Indigo	24” o.c.	Dry-moist	Yellow	2-3’
<i>Blephilia ciliate</i>	Ohio Horsemint	18” o.c.	Dry-moist	Pink	1-2’
<i>Chelone glabra</i>	White Turtlehead	24” o.c.	Wet	White	2-4’
<i>Chelone obliqua</i>	Rose Turtlehead	18” o.c.	Wet	Rose	2-4’
<i>Chrysopsis camporum</i>	Golden Aster	18” o.c.	Dry	Yellow	2-3’
<i>Coreopsis lanceolata</i>	Lance-leaf Coreopsis	18” o.c.	Moist-dry	Yellow	6-8’
<i>Coreopsis palmata</i>	Finger Coreopsis	12” o.c.	Dry-moist	Yellow	2’
<i>Coreopsis triptris</i>	Tall Coreopsis	24” o.c.	Dry-moist	Yellow	2-8’
<i>Echinacea pallida</i>	Pale purple Coneflower	18” o.c.	Dry	Purple	2-3’
<i>Echinacea paradoxa</i>	Yellow Coneflower	18” o.c.	Dry	Yellow	2-3’
<i>Echinacea purpurea</i>	Purple Coneflower	18” o.c.	Moist-dry	Purple	3-4’
<i>Equisetum hyemale</i>	Horsetail	30” o.c.	Wet-moist	Green	2-4’



**Table 2 : Native Perennials– Full Sun**

Latin Name	Common Name	Spacing	Moisture	Color	Height
<i>Eryngium yuccifolium</i>	Rattlesnake Master	18" o.c.	Dry-moist	Green	4-5'
<i>Eupatorium coelestinum</i>	Mist Flower	18" o.c.	Moist	Purple	1-2'
<i>Eupatorium perfoliatum</i>	Boneset	24" o.c.	Wet	White	3-5'
<i>Eupatorium purpureum</i>	Joe-Pye Weed	24" o.c.	Wet-moist	Purple	3-6'
<i>Eurybia paludosa</i>	Southern Prairie Aster	18" o.c.	Dry-Moist	Purple	1-2'
<i>Gentiana andrewsii</i>	Bottle Gentian	18" o.c.	Moist-wet	Blue	1-2'
<i>Helenium autumnale</i>	Sneezeweed	24" o.c.	Moist-wet	Yellow	2-4'
<i>Helianthus salicifolius</i>	Willow-leaved Sunflower	24" o.c.	Dry-moist	Yellow	4-6'
<i>Heliopsis helianthoides</i>	Ox-eye Sunflower	24" o.c.	Wet-dry	Yellow	3-5'
<i>Heuchera americana</i>	American Alumroot	18" o.c.	Dry-moist	Cream	1'
<i>Heuchera parviflora</i>	Late-flowering Alumroot	18" o.c.	Dry-moist	White	1'
<i>Heuchera richardsonii</i>	Prairie Alumroot	18" o.c.	Dry-wet	Cream	1'
<i>Heuchera villosa</i>	Maple-leaf Alumroot	18" o.c.	Dry-moist	White	1'
<i>Hibiscus lasiocarpus</i>	Rose Mallow	24" o.c.	Wet	White/Pink	3-4'
<i>Iris brevicaulis</i>	Zig-zag Iris	12" o.c.	Wet-dry	Purple	0.5-1'
<i>Iris cristata</i>	Dwarf Crested Iris	12" o.c.	Dry	Violet	1'
<i>Iris fulva</i>	Copper Iris	12" o.c.	Wet	Red	2'
<i>Iris virginica</i>	Southern Blue Flag Iris	18" o.c.	Moist-Wet	Blue/Purple	2'
<i>Lespedeza virginica</i>	Slender Bush Clover	18" o.c.	Dry-moist	Pink	1-2'
<i>Liatris aspera</i>	Rough Blazingstar	18" o.c.	Moist-dry	Purple	2-5'
<i>Liatris pycnostachya</i>	Prairie Blazingstar	18" o.c.	Wet-Moist	Purple	1-4'
<i>Liatris scariosa</i>	Eastern Blazingstar	12" o.c.	Moist-dry	Purple	2-4'
<i>Liatris spicata</i>	Marsh Blazingstar	18" o.c.	Wet-dry	Purple	2-3'
<i>Lobelia cardinalis</i>	Cardinal Flower	18" o.c.	Wet-moist	Red	2-4'
<i>Lobelia siphilitica</i>	Blue Lobelia	12" o.c.	Wet-moist	Purple	2-3'
<i>Mimulus ringens</i>	Allegheny Monkey Flower	18" o.c.	Moist-wet	Lavender	1-2'
<i>Monarda didyma</i>	Bee Balm	24" o.c.	Wet-moist	Red	3'
<i>Monarda fistulosa</i>	Wild Bergamot	18" o.c.	Moist	Purple	1-3'



**Table 2 : Native Perennials– Full Sun**

Latin Name	Common Name	Spacing	Moisture	Color	Height
<i>Packera obovata</i>	Golden Groundsel (Squaw Weed)	12" o.c.	Wet-Moist	Yellow	1'
<i>Parthenium integrifolium</i>	Wild Quinine	18" o.c.	Dry-moist	White	2-4'
<i>Penstemon cobaea</i>	Purple Beard Tongue	12" o.c.	Moist-Dry	Purple	1-2'
<i>Penstemon digitalis</i>	Foxglove Beard Tongue	18" o.c.	Moist-Dry	White	2.5-4'
<i>Phlox maculata</i>	Meadow Phlox	12" o.c.	Wet-Moist	Pink/Rose	2-3'
<i>Phlox paniculata</i>	Garden Phlox	24" o.c.	Wet-Moist	Pink/Rose	3-4'
<i>Pycnanthemum pilosum</i>	Hairy Mountain Mint	18" o.c.	Moist-Dry	White	2-4'
<i>Pycnanthemum tenuifolium</i>	Slender mountain mint	18" o.c.	Moist	White	1.5-2.5'
<i>Ratibida pinnata</i>	Yellow/Grey Coneflower	18" o.c.	Dry-Moist	Yellow	3-5'
<i>Rudbeckia fulgida</i>	Orange Coneflower	24" o.c.	Wet-Moist	Yellow	1.5-2.5'
<i>Rudbeckia hirta</i>	Black-eyed Susan	18" o.c.	Moist-dry	Yellow	3'
<i>Rudbeckia subtomentosa</i>	Sweet Coneflower	24" o.c.	Wet-Dry	Yellow	4-6'
<i>Salvia azurea</i>	Blue Sage	24" o.c.	Moist-Dry	Blue	3-4'
<i>Sagittaria latifolia</i>	Arrowleaf	30" o.c.	Wet	White	1-4'
<i>Scutellaria incana</i>	Downy Skullcap	18" o.c.	Dry-moist	Blue	2-3'
<i>Senna (cassia) marilandica</i>	Wild Senna	24" o.c.	Moist-dry	Yellow	3-5'
<i>Silene regia</i>	Royal Catchfly	12" o.c.	Moist-Dry	Red	2-3'
<i>Silphium perfoliatum</i>	Cup Plant	36" o.c.	Wet-dry	Yellow	7-10'
<i>Solidago nemoralis</i>	Old Field Goldenrod	18" o.c.	Dry-moist	Yellow	4-6'
<i>Solidago rigida</i>	Stiff Goldenrod	12" o.c.	Moist-dry	Yellow	3-4'
<i>Solidago rugosa</i>	Rough-Leaved Goldenrod	18" o.c.	Dry-moist	Yellow	2-3'
<i>Solidago speciosa</i>	Showy Goldenrod	18" o.c.	Moist-dry	Yellow	3-4'
<i>Symphyotrichum laeve</i>	Smooth Aster	18" o.c.	Wet-dry	Blue/ Purple	2-3'
<i>Symphyotrichum novae-angliae</i>	New England Aster	24" o.c.	Wet-moist	Purple	2.5-5'
<i>Symphyotrichum oblongifolium</i>	Aromatic Aster	24"	Dry-moist	Purple	1-3'
<i>Symphyotrichum oolentangiense (azureus)</i>	Sky Blue Aster	18" o.c.	Moist-dry	Blue	2-3'
<i>Tephrosia virginiana</i>	Goatsbeard	12" o.c.	Dry-moist	Green	1-2'



**Table 2 : Native Perennials– Full Sun**

Latin Name	Common Name	Spacing	Moisture	Color	Height
<i>Verbesina helianthoides</i>	Yellow Wingstem	18" o.c.	Dry-moist	Yellow	2-3'
<i>Veronacastrum virginicum</i>	Culver's Root	24" o.c.	Dry	White	3-6'
<i>Zizia aptera</i>	Golden Alexander	12" o.c.	Wet-moist	Yellow	1-1.5'

**Table 3 : Native Perennials– Shade**

Latin Name	Common Name	Spacing	Moisture	Color	Height
<i>Asarum canadense</i>	Wild Ginger	12" o.c.	Moist	Green	4"
<i>Cimifuga racemosa</i>	Black Cohosh	24" o.c.	Moist	White	5-7'
<i>Claytonia virginica</i>	Spring Beauty	4" o.c.	Wet-dry	White	5-10"
<i>Coreopsis palmata</i>	Prairie Coreopsis	12" o.c.	Moist-dry	Yellow	1.5-2.5'
<i>Erythronium americanum</i>	Yellow Trout Lily	4" o.c.	Moist	Yellow	6-12"
<i>Isopyrum biternatum</i>	False Rue Anemone	6" o.c.	Moist-wet	White	5-8"
<i>Mertensia virginica</i>	Virginia Bluebells	12" o.c.	Moist	Blue/Purple /White	1-2'
<i>Packera aurea</i>	Golden Ragwort	12" o.c.	Moist	Yellow	0.5-1'
<i>Packera obovata</i>	Golden Groundsel	12" o.c.	Moist	Yellow	1'
<i>Phlox divaricate</i>	Wild Sweet William	12" o.c.	Moist-dry	Purple	1'
<i>Polemonium reptans</i>	Jacob's Ladder	12" o.c.	Moist	Blue	1'
<i>Polygonatum biflorum</i>	Solomon's Seal	12" o.c.	Moist-dry	White	2-4'
<i>Spigelia marilandica</i>	Indian Pink	12" o.c.	Moist-dry	Green	1.5-2.5'
<i>Stylophorum diphyllum</i>	Celandine Poppy	18" o.c.	Moist	Yellow	1-1.5'



**Table 4 : Native Grasses and Sedges**

Latin Name	Common Name	Spacing	Moisture	Color	Height
<i>Andropogon gerardii</i>	Big Bluestem	24" o.c.	Moist-Dry	Green	5-9'
<i>Andropogon virginicus</i>	Broomsedge	18" o.c.	Dry	Green	1-2'
<i>Andropogon ternarius</i>	Splitbeard Bluestem	18" o.c.	Dry	Green	1-2'
<i>Bouteloua curtipendula</i>	Sideoats Grama	12" o.c.	Dry-moist	Yellow	1-2'
<i>Bouteloua gracilis</i>	Blue Gamma Grass	18" o.c.	Moist-Dry	Green/Yellow	1-2'
<i>Carex albicans</i>	Oak Sedge	18" o.c.	Moist	Green	1'
<i>Carex annectans</i>	Yellow Fruited Sedge	18" o.c.	Wet-moist	Green	2-3'
<i>Carex crinita</i>	Fringed Sedge	18" o.c.	Wet-moist	Green	2-3'
<i>Carex grayii</i>	Globe Sedge	18" o.c.	Moist-wet	Green	1-1.5'
<i>Carex eburnea</i>	Bristle-leaf Sedge	12" o.c.	Moist	Green	1'
<i>Carex hirsutella</i>	Fuzzy Wuzzy Sedge	12" o.c.	Dry-moist	Green	1'
<i>Carex pennsylvanica</i>	Pennsylvania Sedge	18" o.c.	Moist	Green	1'
<i>Carex muskingumensis</i>	Palm Sedge	18" o.c.	Moist-wet	Green	2-3'
<i>Carex praegracilis</i>	Tollway Sedge	24" o.c.	Dry-Wet	Green	2'
<i>Carex shortiana</i>	Short's Sedge	18" o.c.	Dry-wet	Green	1-2'
<i>Carex stricta</i>	Tussock Sedge	18" o.c.	Wet	Green	1-1.5'
<i>Carex vulpinoidea</i>	Fox Sedge	18" o.c.	Moist-wet	Green	2-3'
<i>Chasmanthium latifolium</i>	Northern Sea Oats / River Oats	24" o.c.	Wet-moist	Green	2-2.5'
<i>Diarrhena obovate</i>	American Beakgrain	16" o.c.	Wet-dry	Green	1.5-2.5'
<i>Elymus canadensis</i>	Canada Wild Rye	24" o.c.	Dry	Green	3-5'
<i>Juncus biflorus</i>	Bog rush	12" o.c.	Moist-wet	Green	2'
<i>Juncus effuses</i>	Soft Rush	18" o.c.	Moist-wet	Green	2-3'
<i>Juncus tenuis</i>	Path Rush	12" o.c.	Wet-moist	Green	6-12"
<i>Panicum virgatum</i>	Switch Grass	24" o.c.	Moist-dry	Green	3-6'
<i>Scirpus atrovirens</i>	Great Green Bullrush	18" o.c.	Wet	Green	2-3'
<i>Scirpus cyperinus</i>	Wool Grass	18" o.c.	Wet	Green	3-4'
<i>Schizachyrium scoparium</i>	Little Bluestem	12" o.c.	Moist-dry	Green/Blue	2-3'
<i>Sorghastrum nutans</i>	Indian Grass	24" o.c.	Moist-dry	Green/Blue	3-6'



**Table 4 : Native Grasses and Sedges**

Latin Name	Common Name	Spacing	Moisture	Color	Height
<i>Spartina pectinate</i>	Prairie Cordgrass	30" o.c.	Moist-wet	Green	4-5'
<i>Sporobolus heterolepis</i>	Prairie Dropseed	24" o.c.	Moist-dry	Green	1.5-2.5'
<i>Tripsacum dactyloides</i>	Eastern Gama Grass	4' o.c.	Wet	Green	4-8'

**Table 5 : Native Medium Shrubs**

Latin Name	Common Name	Spacing	Sun	Moisture	Flower Color	Height	Notes
<i>Aronia melanocarpa</i>	Black Chokeberry	5-9'		Dry-Wet	White	5-9'	Food for Birds and Small Animals
<i>Callicarpa americana</i>	American Beautyberry	3'	Full Sun/ Avg Shade	Dry-moist	Purple	4-5'	Ornamental Fresh-cut Flowers Berries attract songbirds
<i>Ceanothus americanus</i>	New Jersey Tea	2'	Full Sun/ Avg Shade	Dry-moist	White	2-4'	Edible leaves can be brewed into tea when dried. Food for Birds and Small Animals
<i>Cephalanthus occidentalis</i>	Buttonbush	6'	Full Sun/ Avg Shade	Wet	White	6-10'	Fragrant flowers attract butterflies and other pollinators
<i>Dirca palustris</i>	Leatherwood	3'	Shade	Wet-moist	-	4-7'	Food for birds
<i>Euonymus americanus</i>	Strawberry Bush	5'	Shade	Wet-moist	Red	6-8'	Food for birds Attracts songbirds and butterflies
<i>Hydrangea arborescent</i>	Wild Hydrangea	4'	Full Sun/ Shade	Moist-dry	White	4-5'	Fresh cut flowers Attracts butterflies and other pollinators
<i>Hypericum prolificum</i>	Shrubby St. Johns Wort	2'	Full Sun/ Avg Shade	Dry-moist	Yellow	3-5'	Fresh cut flowers Attracts butterflies and other pollinators
<i>Ilex verticillate</i>	Winterberry Holly	4'	Full Sun/ Avg Shade	Wed-dry	Green	6-10'	Ornamental Food for birds and small animals
<i>Lindera benzoin</i>	Spicebush	6'	Full Sun/ Avg Shade	Wet-moist	Yellow	6-12'	Attracts butterflies and other pollinators
<i>Physocarpus opulifolius</i>	Ninebark	6'	Full Sun	Wet-moist	White	5-10'	Attracts butterflies and other pollinators





Table 5 : Native Medium Shrubs							
Latin Name	Common Name	Spacing	Sun	Moisture	Flower Color	Height	Notes
<i>Rhus aromatica</i>	Fragrant Sumac	6'	Full Sun/ Avg Shade	Dry-moist	Red	2-6'	Food for birds and small animals
<i>Ribes odoratum</i>	Golden Currant	5'	Full Sun/ Avg Shade	Dry-moist	Yellow	4-6'	Edible fruit Attracts butterflies and other pollinators
<i>Sambucus canadensis</i>	Elderberry	5'	Full Sun/ Avg Shade	Wet-moist	White	5-12'	Edible fruit Attracts butterflies and other pollinators

Table 6 : Native Large Shrubs							
Latin Name	Common Name	Spacing	Sun	Moisture	Flower Color	Height	Notes
<i>Amelanchier arborea</i>	Serviceberry	10'		Dry-moist	White	15-25'	Large shrub can be pruned into small tree. Attracts songbirds Edible fruit
<i>Cornus racemose</i>	Gray Dogwood	10'	Full Sun/ Shade	Dry-moist	Red/ White	10-15'	Attracts songbirds
<i>Corylus Americana</i>	American Hazelnut	8'	Full Sun/ Avg Shade	Dry-moist	Yellow	8-12'	Edible nuts
<i>Euonymus atropurpureus</i>	Wahoo	8'	Full Sun/ Avg Shade	Dry-moist	Purple	12-20'	Food for birds
<i>Hamamelis virginiana</i>	Witch Hazel	15'	Full Sun/ Shade	Dry-moist	Yellow	15-20'	Food for birds Attracts butterflies and other pollinators
<i>Ilex decidua</i>	Deciduous Holly	5'	Full Sun/ Avg Shade	Dry-moist	Red/ White	10-15'	Ornamental Food for birds and small animals
<i>Prunus virginiana</i>	Chokeberry	15'	Shade/ Avg Shade	Wet-dry	White	20-30'	Edible Fruit Attracts butterflies and other pollinators
<i>Viburnum prunifolium</i>	Black Haw Viburnum	8'	Full Sun	Wet-dry	White	12-15'	Food for birds and small animals Attracts butterflies and other pollinators



**Table 7 : Native Small-Medium Trees**

Latin Name	Common Name	Spread	Sun	Moisture	Flower Color	Height	Notes
<i>Acer rubrum</i>	Red Maple	30-60'	Full Sun/ Avg Shade	Dry-moist		40-70'	Fall color
<i>Acer saccharum</i>	Sugar Maple	50-60'	Full Sun/ Avg Shade	Dry		40-75'	
<i>Asimina trilobal</i>	Paw Paw	15-20'	Full Sun/ Avg Shade	Moist-wet	Purple	15-30'	Edible fruit Plant is larval food of Zebra Swallowtail butterfly
<i>Carpinus caroliniana</i>	American Hornbeam	20-50'	Full Sun/ Shade	Moist-wet		20-40'	
<i>Cercis canadensis</i>	Eastern Redbud	25-35'	Full Sun/ Avg Shade	Moist-dry	Pink/ Rose	20-30'	Ornamental
<i>Chionanthus virginicus</i>	Fringetree	5-8'	Full Sun/ Avg Shade	Dry-moist	White	8-10'	Plants of Merit winner by Missouri Botanical Garden. Shimmering, white frothy flowers Can be grown as a large shrub.
<i>Cornus drummondii</i>	Roughleaf Dogwood	6-12'	Full Sun/ Avg Shade	Dry-moist	White	8-15'	Can be grown as a large shrub Food for birds and small animals
<i>Cornus florida</i>	Flowering Dogwood	15-30'	Full Sun/ Avg Shade	Moist	White	15-30'	Missouri State Tree Ornamental
<i>Crataegus mollis</i>	Downy Hawthorn	20-30'	Full Sun/ Avg Shade	Dry-moist	White	20-30'	Ornamental Food for birds and small animals
<i>Crataegus viridis</i>	Green Hawthorn	20-35'	Full Sun	Wet-Moist	White	20-35'	Ornamental Food for birds and small animals
<i>Prunus americana</i>	Wild Plum	8-20'	Full Sun/ Avg Shade	Dry-moist	White	8-20'	Ornamental Edible fruit Host to Red- spotted Purple Butterfly and many moths



**Table 7 : Native Medium-Large Trees**

Latin Name	Common Name	Spread	Sun	Moisture	Flower Color	Height	Notes
<i>Acer rubrum</i>	Red Maple	30-60'	Full Sun/ Avg Shade	Dry-moist		40-70'	Fall color
<i>Acer saccharum</i>	Sugar Maple	50-60'	Full Sun/ Avg Shade	Dry		40-75'	
<i>Asimina trilobal</i>	Paw Paw	15-20'	Full Sun/ Avg Shade	Moist-wet	Purple	15-30'	Edible fruit Plant is larval food of Zebra Swallowtail butterfly
<i>Betula nigra</i>	River Birch	40-60'	Full Sun	Dry-wet		40-70'	Peeling bark
<i>Carya ovata</i>	Shagbark Hickory	40-60'	Full Sun/ Shade	Dry-moist		60-80'	Edible nuts Bark peels off in thin sections, curling at the ends while staying attached in the middle
<i>Celtis occidentalis</i>	Hackberry	40-60'	Full Sun	Dry-wet		40-60'	Use as a shade tree in large areas
<i>Diospyros virginiana</i>	Persimmon	20-35'	Full Sun/ Avg Shade	Moist		35-60'	Edible fruit
<i>Platanus occidentalis</i>	Sycamore	75-100'	Full Sun	Wet-moist		75-100'	Shade Tree
<i>Quercus alba</i>	White Oak	50-90'	Full Sun	Dry-moist		50-80'	Shade tree
<i>Quercus bicolor</i>	Swamp White Oak	50-70'	Full Sun/ Avg Shade	Wet-dry		50-80'	Shade tree
<i>Quercus macrocarpa</i>	Bur Oak	70-80'	Full Sun/ Avg Shade	Wet-dry		70-80'	Shade tree
<i>Quercus palustris</i>	Pin Oak	25-40'	Full Sun/ Avg Shade	Wet-moist		60-70'	Shade tree
<i>Taxodium distichum</i>	Bald Cypress	20-30'	Full Sun/ Avg Shade	Wet-moist		50-70'	Tolerates a wide range of conditions ranging from relatively dry soil to wet soil and standing water



---

## RELATED LINKS AND RESOURCES

---

For an up-to-date list of native plant sources:

- Grow Native! [www.grownative.org](http://www.grownative.org), by the Missouri Prairie Foundation

Additional Web Resources:

- Missouri Department of Conservation, [mdc.mo.gov/trees-plants](http://mdc.mo.gov/trees-plants)
- Missouri Prairie Foundation, [www.moprairie.org](http://www.moprairie.org)
- Shaw Nature Reserve, [www.shawnature.org](http://www.shawnature.org)
- Show Me Rain Gardens, [www.showmeraingardens.org](http://www.showmeraingardens.org)
- Ten Thousand Rain Gardens, [www.rainkc.com](http://www.rainkc.com)
- The Green Center, [www.thegreencenter.org](http://www.thegreencenter.org)
- Missouri Botanical Garden Plant Finder, [www.missouribotanicalgarden.org](http://www.missouribotanicalgarden.org)

Publications:

- Metropolitan St. Louis Sewer District (2014). *Landscape Guide for Stormwater Best Management Practice Design*, St. Louis, MO. [www.stlmsd.com/sites/default/files/engineering/442680.PDF](http://www.stlmsd.com/sites/default/files/engineering/442680.PDF)
- Shaw Nature Reserve, a division of the Missouri Botanical Garden (2011). *A Guide to Native Landscaping*, Gray Summit, MO.
- Missouri Department of Natural Resources (2012). *Missouri Guide to Green Infrastructure*, Jefferson City, MO. [dnr.mo.gov/env/wpp/stormwater/mo-gi-guide.htm](http://dnr.mo.gov/env/wpp/stormwater/mo-gi-guide.htm)



## APPENDIX C

### The Simple Method of Determining Adequate Flow Area

This method is only to be used to determine adequate flow area required for projects that add more than 15,000 square feet of impervious area.

**Step 1:** Determine flow patterns on your project site, specifically where flow exits the project.

**Step 2:** Where flow exits the site, determine existing flow area of the exiting drainage channels on your site using the schematic and equation below in Figure 1. Mark on the plans where flow area was determined.

**Step 3:** Once flow area has been calculated, determine the impervious area (IA) of the project and the nearest lot area to determine the required flow area for your site.

**Step 4:** A) If the result of **Step 2** is *less* than **Step 3** adequate drainage is not present and the developer must follow current MSD guidelines. B) If the result of **Step 2** is *greater* than **Step 3** adequate drainage is present. If B, then the developer must submit calculations and site plan to the Director of Public Services Director for verification.

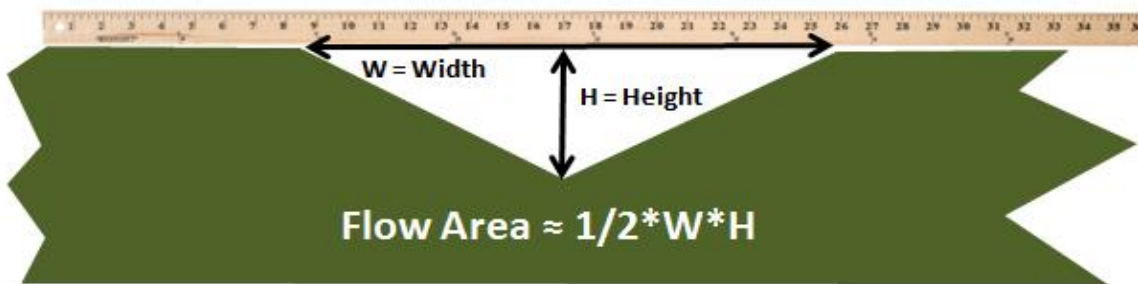

Figure 1 Simple Method - Flow Area Calculation

Table 1 Simple Method - Flow Area Required

Flow Area in Square Feet							
IA (sq ft).	Total lot area -->		1/4 Acre	15,000	1/2 Acre	30,000	1 Acre
	1,000	5,000	10,890		21,780		40,000
1,200	0.12	0.19	0.29	0.36	0.48	0.62	0.80
2,500	0.23	0.30	0.40	0.47	0.59	0.73	0.91
3,000	0.27	0.34	0.44	0.51	0.63	0.78	0.95
4,000	0.35	0.42	0.53	0.60	0.72	0.86	1.03
5,000	0.44	0.51	0.61	0.68	0.80	0.94	1.12
7,500	0.65	0.72	0.82	0.89	1.01	1.15	1.33
10,000	0.86	0.93	1.03	1.10	1.22	1.36	1.54
30,000	2.53	2.60	2.71	2.78	2.90	3.04	3.21
40,000	3.37	3.44	3.54	3.62	3.74	3.88	4.05

Read impervious area on the left then read across to right the nearest TOTAL lot size

Concrete channel flow area is 2/3 of the vegetated channel

## APPENDIX D

### Underdrain Requirements

Some sites within the City have very low infiltration rates due to existing soil conditions and other factors. If your site has an infiltration rate that is less than required for your selected BMP, an underdrain will be required. An underdrain is a perforated pipe that is installed along the center of the BMP that will help the BMP to drain. The underdrain should be perched to allow some storage of water within the BMP before it drains out through the perforated pipe. See the detail below.

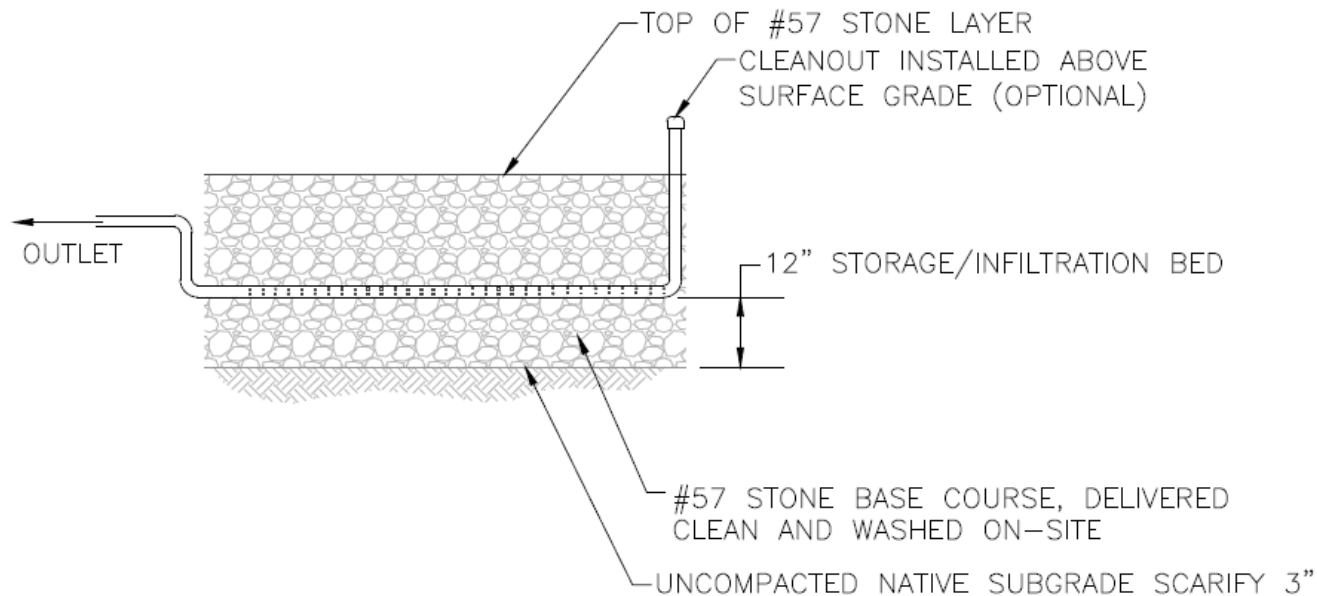

This detail consists of the general configuration of a perched underdrain system, the underdrain within your BMP may vary in size and position.



## APPENDIX E

### **Municipal Code Chapter 5, Article VI. Storm Water Management**

The contents of this manual provide guidelines for meeting the Infill Development Storm Water Management regulations as stated in the municipal code. A copy of the ordinance in its entirety begins on the following page.