



**Landmarks Commission  
Agenda  
Wednesday, May 8, 2024, 6:30 p.m.  
Main Level Conference Room  
Kirkwood City Hall  
139 S. Kirkwood Road  
Kirkwood, MO 63122**

- I. Approval of Minutes of April 10, 2024** and any additions or modifications to the current agenda.
- II. Certificates of Appropriateness – Unfinished Business**
  - a. **Case #1-2022 Amended, 150 W. Argonne Drive** (Landmark #77, Heinzelman Bakery Building, Downtown Kirkwood National Register District) – Changes to rear bar area for 4 Hands/Peacemaker restaurant to screen roof top mechanical units.
- III. Certificates of Appropriateness – New Business**
  - a. **Case #7-2024, 150 W. Argonne Drive** (Landmark #77, Heinzelman Bakery Building, Downtown Kirkwood National Register District) – Projecting building signs for 4 Hands/Peacemaker restaurant.
- IV. New Business**
  - a. Citizens Comments/Seeking Advice to preserve their historic properties
- V. Meeting Adjournment**

**Staff Liaison:** Amy Lowry. Phone: 314-822-5815 Email: [lowryag@kirkwoodmo.org](mailto:lowryag@kirkwoodmo.org)

**Landmarks Commission:** Chair Ryan Molen; Commissioners Michael Karpowicz, Michael Kleckner, Kristy Piasecki, Aaron Senne, Noelle Seymour, Jessica Worley.

**Accommodation:** The City of Kirkwood is interested in effective communication for all persons. Persons requiring an accommodation to attend and participate in the meeting should contact the City Clerk at 314-822-5802 at least 48 hours before the meeting. With advance notice of seven calendar days, the City of Kirkwood will provide interpreter services at public meetings for languages other than English and for the hearing impaired. Upon request, the minutes from this meeting can be made available in an alternate format, such as a CD, by calling 314-822-5802.



**Landmarks Commission  
Minutes  
Wednesday, April 10, 2024, 7:00 p.m.  
City Council Chambers  
Kirkwood City Hall  
139 S. Kirkwood Road  
Kirkwood, MO 63122**

Pursuant to notice of meeting duly given, the Landmarks Commission met in the City Council Chambers. Present: Chair Ryan Molen, Commissioners Michael Karpowicz, Michael Kleckner, Kristy Piasecki, Aaron Senne, Jessica Worley, and Planner II Amy Lowry. The meeting was called to order at 7:00 p.m.

**I. Approval of Minutes** – Motion to approve the March 13, 2024 meeting minutes as submitted by Comr. Worley, seconded by Comr. Karpowicz, and unanimously approved.

**II. Certificates of Appropriateness**

None

**III. New Business**

- a. Citizens Comments/Seeking Advice to preserve their historic properties -none
- b. Favorite Building Awards 2024 – The Commission discussed nominated commercial, multi-family and residential projects and decided upon winners of the awards for the May 8 ceremony.

**IV. Meeting Adjournment** – Motion to adjourn at 7:42 p.m. by Comr. Worley, seconded by Comr. Karpowicz, and unanimously approved.

---

Ryan Molen, Chair



# Kirkwood Landmarks Commission

## Application for Certificate of Appropriateness

Please submit the application with supporting documentation by the first Wednesday of the month to the Building Department. Failure to supply sufficient information may result in the application being denied or postponed. It is recommended that you or your representative be present at the Landmarks Commission meeting on the second Wednesday of the month at 7:00 p.m. in City Hall.

1. Property Address 150 W. Argonne Dr.

2. Property Status
- Local Landmark Designation
  - National Register of Historic Places
  - Within a Historic District

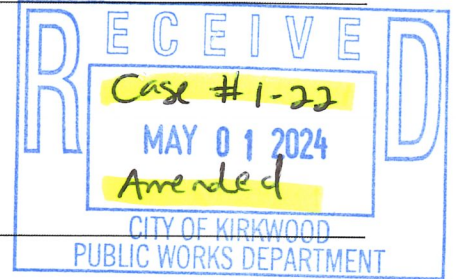

3. Name of Applicant Savoy Properties

Mailing Address 1034 S. Brentwood Blvd., Suite 1200

City/State St. Louis MO Zip Code 63117

Office Phone ( ) Cell Phone ( 314 ) 412-0391

Home Phone ( ) E-Mail dlesinski@savoyproperties.com

4. Relationship of Applicant to Property \_\_\_\_\_

- Owner
- Contractor
- Architect
- Attorney
- Other – Please specify Tenant

5. Existing Building Use Vacant

6. Proposed Building Use Indoor/Outdoor Bar and Restaurant Build Out - Roof Top Unit

7. Proposed Change to  Primary Structure  Accessory Structure  Landscape Element Screening

8. Nature of Proposed Change

- Demolition
- Addition
- Alteration to Exterior
- New Construction
- Other – Please Specify Change to Originally Approved Plan
- Window Configuration
- Sign Erection or Placement
- Fence
- Landscape or Hardscape Element

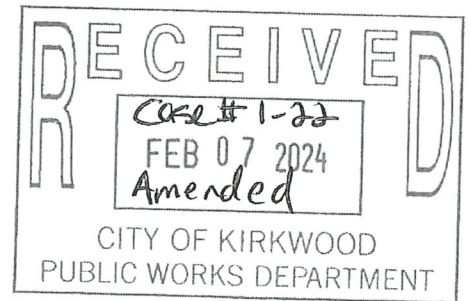

9. Description of Proposed Improvements Please see attached cover letter

\_\_\_\_\_  
\_\_\_\_\_

10. **Accompanying Documentation (8 copies each)**

- Site Plan
- Elevations
- Floor/Building Plans
- Other – Please Specify \_\_\_\_\_
- Structural Report for Demolitions
- Landscape Plan
- Photos

11. **Existing Materials/Construction**

- Wood Frame
- Brick
- Stone
- Block
- Stucco
- Other \_\_\_\_\_

12. **Proposed Materials/Construction**

- Wood Frame
- Brick
- Stone
- Block
- Stucco
- Other \_\_\_\_\_

13. **If materials differ from existing, explain reasons** \_\_\_\_\_

14. **Material samples should be available for review at Commission meeting (preferable) or on site.**

Site Location of Materials \_\_\_\_\_

I understand the work will not begin until the Landmarks Commission completes its review of this application.

Signature *Drew Lesinski* Date 2/6/2024

Please print name Drew Lesinski

---

---

COMMISSION ACTION  Approved *as amended*  Approved with Conditions  Disapproved

Signature *[Signature]* Date 2/14/24

Conditions \_\_\_\_\_

Comments/Recommendations \_\_\_\_\_



## 4Hands at The Station Roof Top Condenser and Screening Plan

Apprx. 4.5—5ft high screen constructed of same corrugated material as seen elsewhere on the project. See attached photo.

3ft opening for access

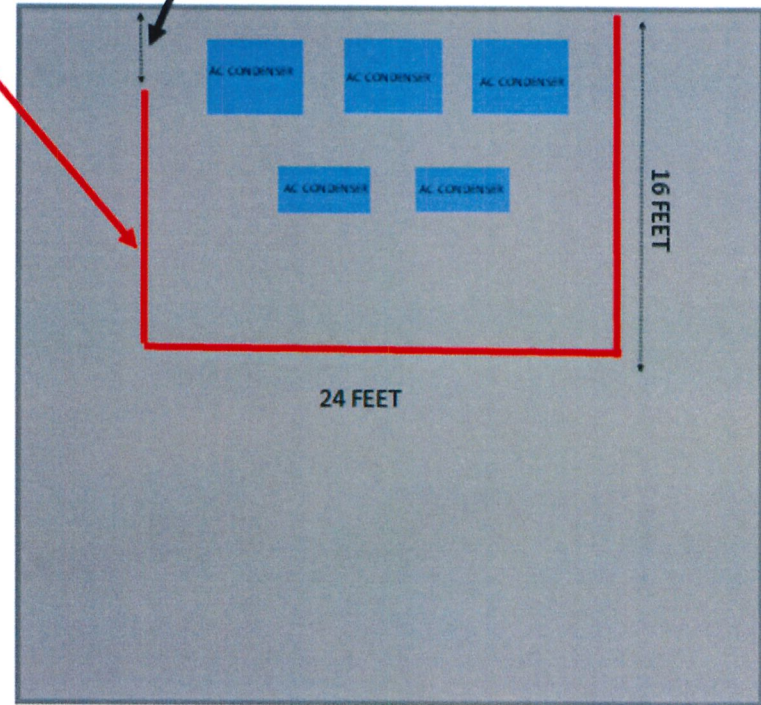



**150 W ARGONNE BAR CONSTRUCTION**



**150 W ARGONNE COOLER/RESTROOM**







# Kirkwood Landmarks Commission

## Application for Certificate of Appropriateness

Please submit the application with supporting documentation by the first Wednesday of the month to the Building Department. Failure to supply sufficient information may result in the application being denied or postponed. It is recommended that you or your representative be present at the Landmarks Commission meeting on the second Wednesday of the month at 7:00 p.m. in City Hall.

1. Property Address 150 W. ARGONNE

2. Property Status  Local Landmark Designation  
 National Register of Historic Places  
 Within a Historic District

3. Name of Applicant DREW LESINSKI

Mailing Address 1034 S BRENTWOOD BLVD.

City/State ST. LOUIS MO Zip Code 63117

Office Phone (314) 412 0391 Cell Phone (314) 412 0391

Home Phone ( ) E-Mail \_\_\_\_\_

4. Relationship of Applicant to Property \_\_\_\_\_  
 Owner  Contractor  Architect  Attorney  
 Other – Please specify \_\_\_\_\_

5. Existing Building Use ~~RESTAURANT~~ VACANT

6. Proposed Building Use RESTAURANT/DAR

7. Proposed Change to  Primary Structure  Accessory Structure  Landscape Element

8. Nature of Proposed Change  
 Demolition  Window Configuration  
 Addition  Sign Erection or Placement  
 Alteration to Exterior  Fence  
 New Construction  Landscape or Hardscape Element  
 Other – Please Specify \_\_\_\_\_

9. Description of Proposed Improvements 2 PROTECTIVE WALL SIGNS -  
2 SIDED

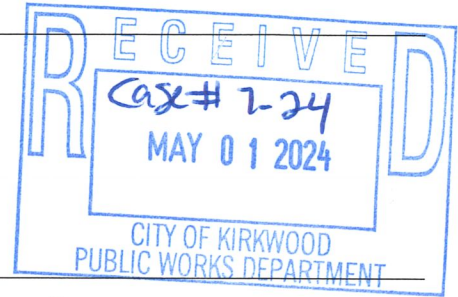

10. **Accompanying Documentation (8 copies each)**

- Site Plan
- Elevations
- Floor/Building Plans
- Other – Please Specify SHOP DRAWINGS
- Structural Report for Demolitions
- Landscape Plan
- Photos

11. **Existing Materials/Construction**

- Stucco
- Other \_\_\_\_\_
- Wood Frame
- Brick
- Stone
- Block

12. **Proposed Materials/Construction**

- Stucco
- Other N/A
- Wood Frame
- Brick
- Stone
- Block

13. **If materials differ from existing, explain reasons** \_\_\_\_\_

14. **Material samples should be available for review at Commission meeting (preferable) or on site.**

Site Location of Materials N/A

I understand the work will not begin until the Landmarks Commission completes its review of this application.

Signature

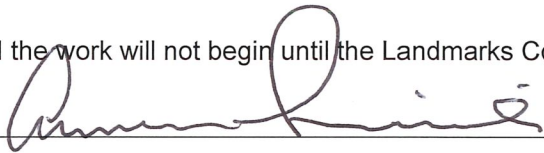

Date

5/5/29

Please print name \_\_\_\_\_

---

---

**COMMISSION ACTION**

Approved

Approved with Conditions

Disapproved

Signature \_\_\_\_\_

Date \_\_\_\_\_

Conditions \_\_\_\_\_

Comments/Recommendations \_\_\_\_\_





SIGN LOCATION #1  
NORTH FACE OF BUILDING

SIGN LOCATION #2  
WEST FACE OF BUILDING

FABRICATED SIGN CABINETS  
WITH EXTERNAL LIGHTING  
MOUNTED PERPENDICULAR  
TO BUILDING WALLS

150 WEST ARGONNE - KIRKWOOD, MO

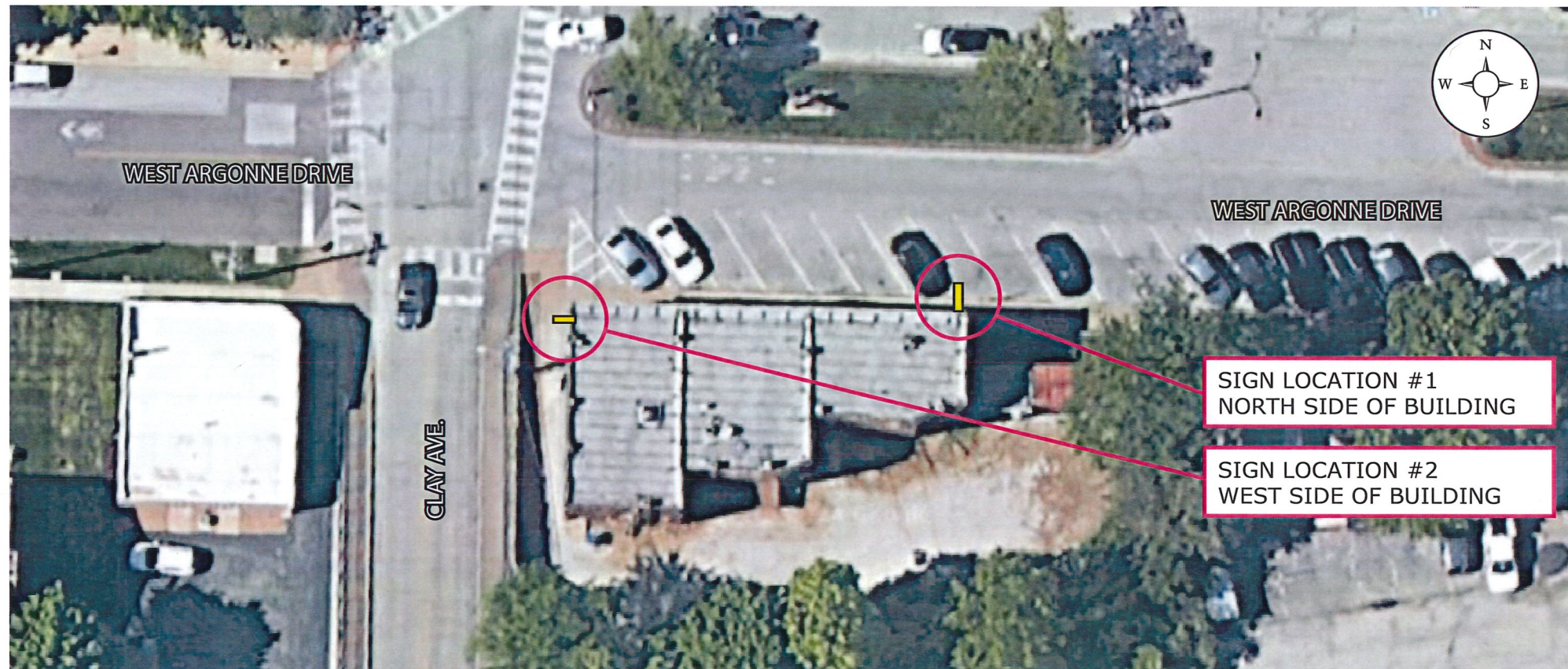

WEST ARGONNE DRIVE

WEST ARGONNE DRIVE

CLAY AVE

SIGN LOCATION #1  
NORTH SIDE OF BUILDING

SIGN LOCATION #2  
WEST SIDE OF BUILDING

150 WEST ARGONNE - KIRKWOOD, MO

**Project:**

PEACEMAKER FOODS  
4 HANDS BREWING  
150 WEST ARGONNE  
KIRKWOOD, MO

**CONCEPT DRAWING -  
NOT FOR PRODUCTION**

This project is confidential and legally privileged. It shall not be copied or disseminated for any unauthorized purpose. The images, information and contents herewith shall not be disclosed or shared.

M.M.

M.G.

**Date:**

February 20, 2024  
March 4, 2024  
March 18, 2024  
April 23, 2024

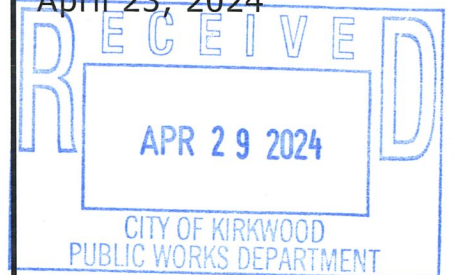



**SIGN LOCATION #1  
NORTH FACE OF BUILDING**



approx  
151"

approx  
30"

approx  
66.7"

**SIGNAGE CALCULATION:**  
30" x 28" = 5.83 sq.ft.  
30" x 43" = 8.95 sq.ft.  
Total = 14.78 sq.ft.

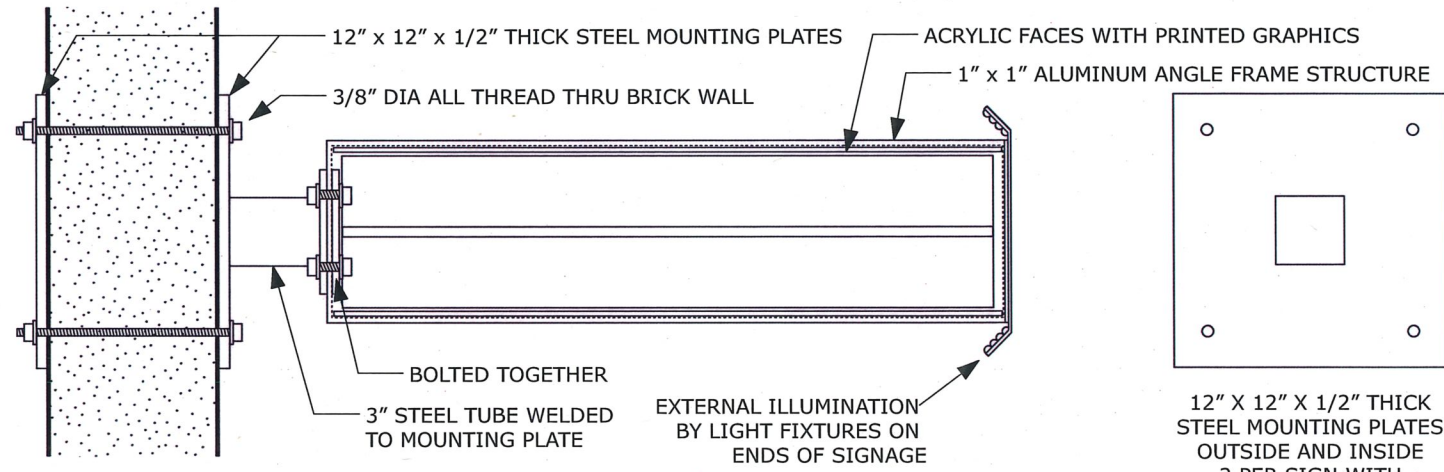

TYPICAL FABRICATION OF EACH SIGN

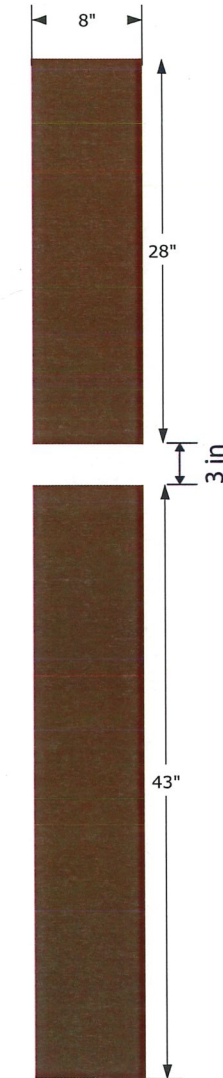
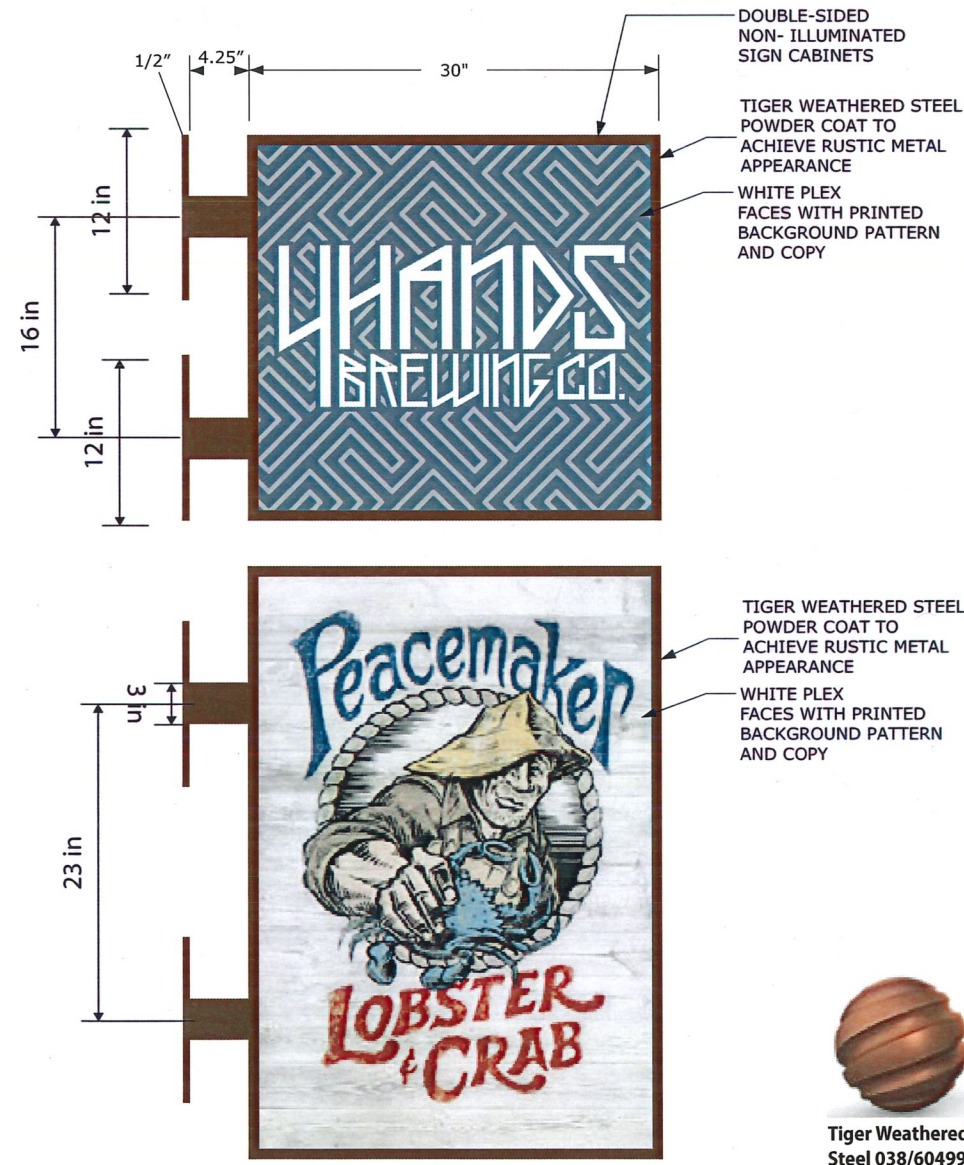

**Project:**  
PEACEMAKER FOODS  
4 HANDS BREWING  
150 WEST ARGONNE  
KIRKWOOD, MO

**SIGN LOCATION #1  
NORTH FACE OF BUILDING**

**CONCEPT DRAWING -  
NOT FOR PRODUCTION**  
This project is confidential and legally privileged. It shall not be copied or disseminated for any unauthorized purpose. The images, information and contents herewith shall not be disclosed or shared.

M.M.

M.G.

**Date:**  
February 20, 2024  
March 4, 2024  
March 18, 2024  
April 23, 2024



**SIGN LOCATION #2  
WEST FACE OF BUILDING**



**SIGNAGE CALCULATION:**  
 $30'' \times 28'' = 5.83 \text{ sq.ft.}$   
 $30'' \times 43'' = 8.95 \text{ sq.ft.}$   
 Total = 14.78 sq.ft.

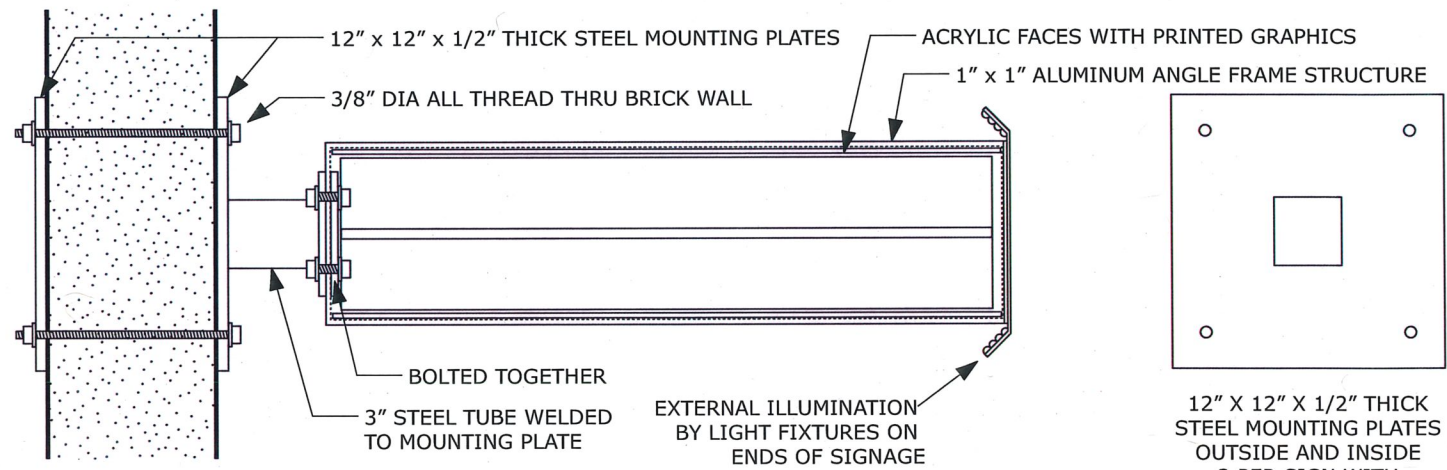

**TYPICAL FABRICATION OF EACH SIGN**

12" X 12" X 1/2" THICK STEEL MOUNTING PLATES OUTSIDE AND INSIDE 2 PER SIGN WITH 4 ANCHOR RODS THRU BRICK WALL

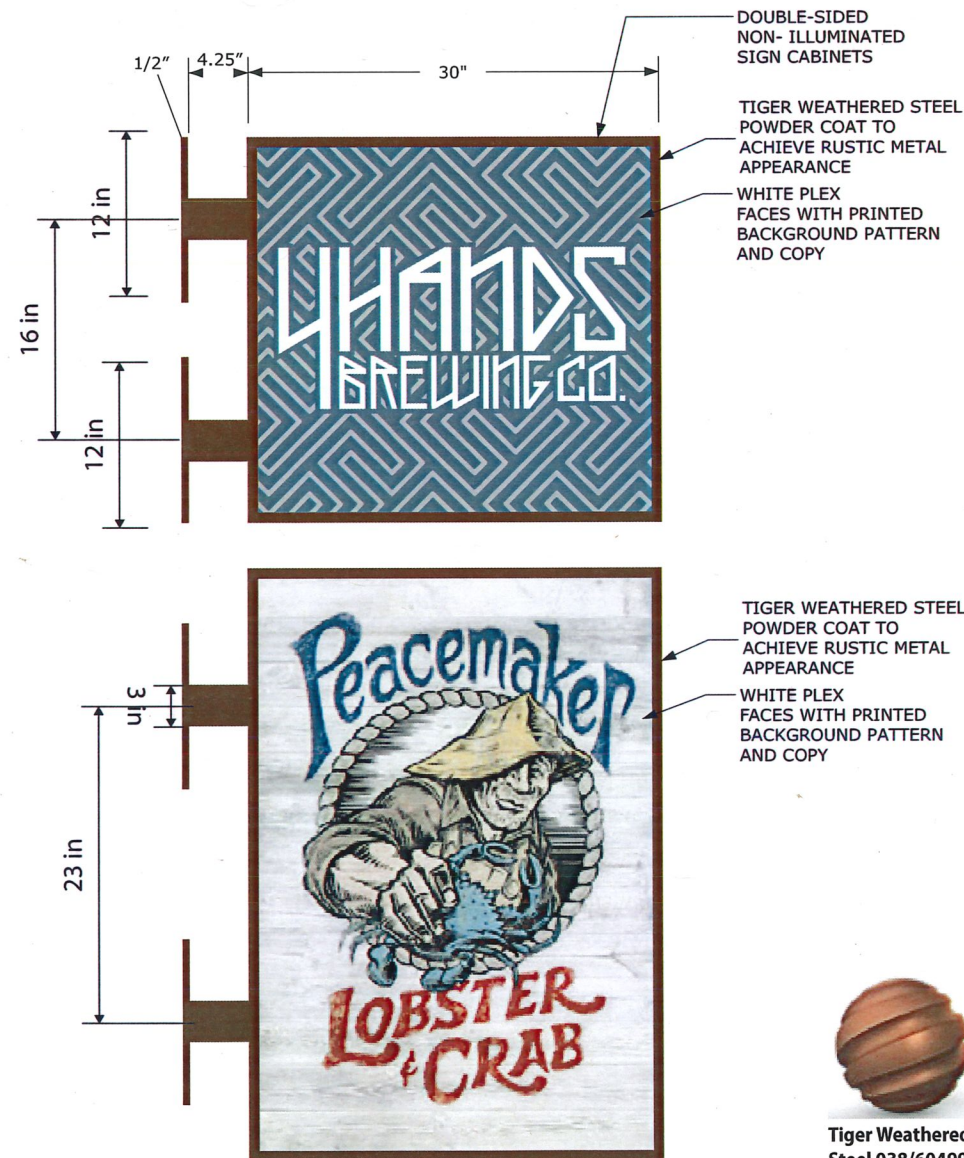

**Tiger Weathered Steel 038/60499**

**Project:**  
 PEACEMAKER FOODS  
 4 HANDS BREWING  
 150 WEST ARGONNE  
 KIRKWOOD, MO

**SIGN LOCATION #2  
WEST FACE OF BUILDING**

**CONCEPT DRAWING - NOT FOR PRODUCTION**  
 This project is confidential and legally privileged. It shall not be copied or disseminated for any unauthorized purpose. The images, information and contents herewith shall not be disclosed or shared.

M.M.

M.G.

**Date:**  
 February 20, 2024  
 March 4, 2024  
 March 18, 2024  
 April 23, 2024