

CITY OF KIRKWOOD WATER DEPARTMENT SPECIFICATIONS

INSTALLATION OF WATER TAPS, SERVICE LINES, CURB STOP VALVES, CURB BOXES, METERS, METER SETTERS, METER BOXES AND METER VAULTS; TAP DESTROYS

Specifications are subject to change without notice.

LOCATION OF UNDERGROUND FACILITIES

- 1) Contractors requiring the location and marking of water mains and taps must call Missouri One-Call at 1-800-DIG-RITE (344-7483). Contractors requiring the marking of **tap** locations must specifically request the location and marking of the **tap** when notifying Missouri One-Call. If not, only the water main will be located and marked. Since the City does not own water service lines (lines between the tap and the building), it will not locate these lines.

NEW TAPS AND REPLACEMENT TAPS

- 1) Contractors shall provide and install the proper type and size CC clamp or service saddle and corporation stop for all water taps or service connections. It is the contractor's responsibility to determine the size and outside pipe diameter of the water main to be tapped.
- 2) Minimum tap size is 1" diameter.
- 3) Taps are available in sizes of 1", 1 ½" and 2". 1 ¼" taps are not available. Only single taps are made. "Manifold" taps are not available.

Tap size diameter shall be in accordance with the following schedule:

<u>Service Line Diameter</u>	<u>Minimum Tap Diameter Allowed</u>
1"	1"
1 ¼"	1"
1 ½"	1 ½"
2"	2"
3"	4"
4"	4"
6"	6"
8"	8"
12"	12"

- 4) All 1" service line taps on cast iron or ductile iron water mains ranging from 2" to 10" in diameter shall be completed using a Smith Blair CC clamp, style #238. Any water mains

larger than 10" in diameter will require a Mueller BR2B Bronze service saddle with AWWA taper thread or Ford Equivalent.

- 5) All 1" service line taps on PVC mains shall be completed using a Ford S-90 Hinge Free style Bronze service saddle, 2-piece bolted or Mueller equivalent.
- 6) All 1 ½ and 2" taps on cast iron or ductile iron mains shall be completed using Mueller BR2B series double strap Bronze service saddle with AWWA taper thread or Ford equivalent.
- 7) All 1 ½ and 2" taps on PVC mains shall be completed using a Mueller or Ford Hinge Free Bronze service saddle, 2 piece bolted.
- 8) All saddles and CC clamps shall be installed at 10 o'clock or two o'clock positions on the water main diameter.
- 9) Three piece saddles **are not permitted**.
- 10) No leaks shall be visible from the corporation stop threads, valve, bend, or service pipe connection.
- 11) Valve on corporation stop shall be in the **fully** open position.
- 12) Corporation stop/service connection shall be supported with blocking by use of two (2) blocks (min.) on a solid rock base. The rock base shall be 1" clean rock, having a minimum depth of 6". The lowest two (2) layers shall be blocks or bricks to provide a stable base. The uppermost layer shall be wood to provide a cushion for the corporation stop/service pipe connection.
- 13) Drawings or sketches **must** be submitted to the Water Department **prior** to the commencement of any work. They shall indicate the proposed location of the service line, tap, curb box, meter box, and service line entry into the building. Drawings/sketches shall also indicate the existing location of the building, water main, curbs, street, public and private sidewalks, and driveway. Water Department approval of these drawings/sketches **must** be obtained **prior** to the commencement of any work.
- 14) All taps shall be front facing to the residence unless an obstruction exists. "Back-taps" (taps made on the opposite side of the main from the building) shall **not** be made without **prior** approval from the Water Department.
- 15) Taps will not be **scheduled** until the tap has been paid for (typically when the permit is obtained) and a utility account for that address has been established at City Hall. Replacement taps need not establish a utility account.
- 16) 1" taps require at least one full business day lead-time. 1 ½ and 2" taps require at least two full business days lead-time.

- 17) Taps shall not be completed until the proper style and size service saddle or CC clamp, entire service line, including the meter, meter box, curb stop and box have been installed.
- 18) Applicable permits must be obtained from the Building Commissioner's Office prior to commencement of any work.

NEW SERVICE LINES AND REPLACEMENT SERVICE LINES

- 1) Service lines shall be 1" minimum diameter from the water main tap up to and through the foundation wall.
- 2) Service lines shall be "K" type copper from the main to the meter. All soldered fittings shall be silver soldered.
- 3) Service lines shall have a minimum of 42" of cover.
- 4) Service lines shall be completely free of kinks and crimps.
- 5) Service lines shall be laid in a straight line from the tap to the house, and shall be perpendicular to the front wall of the building and to the street. If a service line cannot be installed in a straight line, approval from the Water Department **must** be obtained **prior** to its installation. Variances to this rule, if approved, apply only to the portion of service line between the meter box and building only. The service line between the tap and meter box must always be installed in a straight line and perpendicular to the street and the front wall of the building; no exceptions.
- 6) Upon Water Department approval of "back-taps", service lines to "back-taps" shall be installed **beneath** the water main, shall not loop further than 18" around the water main, and shall be completed with use silver soldered 90 degree bends.
- 7) Complete service line replacements require any inside water meter to be replaced with an outside meter setting.
- 8) Replacement service lines shall not use the existing corporation stop unless the existing corporation stop 1) is at least 1 inch minimum diameter; 2) is no more than ¼ inch diameter smaller than the replacement service line; 3) uses a flare copper connection.
- 9) Existing meter boxes or vaults that are removed from service must be abandoned by removing frames, covers and lids, removing the upper portion of the box or vault to a minimum depth of one foot below grade, and backfilling.
- 10) Drawings or sketches **must** be submitted to the Water Department **prior** to the commencement of any work. They shall indicate the proposed location of the service line, tap, curb box, meter box, and service line entry into the building. Drawings/sketches shall also indicate the existing location of the building, water main, curbs, street, public and private sidewalks, and driveway. Water Department approval of these drawings/sketches **must** be obtained **prior** to the commencement of any work.

- 11) Applicable permits must be obtained from the Building Commissioner's Office prior to the commencement of any work.
- 12) All water service line work outside of the building shall be inspected by the Water Department prior to any backfill.

SERVICE LINE REPAIRS/PARTIAL REPLACEMENTS

- 1) Crimping a service line as a means of shutting the water off is only permitted as an emergency measure. Crimps **must** be removed by cutting that portion of service line out and replacing it.
- 2) Flared, pac-joint, or silver soldered fittings are allowed. All copper to copper connections shall be either flared or silver soldered. Connections from copper to lead shall be made using a flared connection on the copper side.
- 3) Any service line repair that requires the partial replacement of the service line, either from the property line to the house, or from the tap to the property line, shall be replaced with one-inch minimum "K" type copper.
- 4) Any service line repair that requires a partial service line replacement within a 10-foot distance from the property line toward the building shall require the water meter location be moved outside if the existing water meter is in the basement.
- 5) Service line "spot" repairs or small "patches" less than 10 feet in length may be made using $\frac{3}{4}$ inch "K" type copper.
- 6) "Spot" repairs or small "patches" on service lines 1" or larger in diameter shall be made using similar size piping.
- 7) Any service line repair that requires the partial replacement of the service line up to and including either meter connection shall require the installation of a new regulation meter yoke/setter.
- 8) Any service line repair that requires a partial replacement of the service line to the existing corporation stop shall not use the existing corporation stop unless the existing corporation stop 1) is at least 1 inch minimum diameter; 2) is no more than $\frac{1}{4}$ inch smaller than the replacement service line; 3) uses a flare copper connection.
- 9) Existing meter boxes or vaults that are removed from service must be abandoned by removing frames, covers and lids, removing the upper portion of the box or vault to a minimum depth of one foot below grade, and backfilling.
- 10) When any service line repair requires a partial replacement of the service line, drawings or sketches **must** be submitted to the Water Department **prior** to the commencement of any work. They shall indicate the proposed location of the service line, tap, curb box, meter box, and service line entry into the building. Drawings/sketches shall also indicate the existing location of the building, water main, curbs, street, public and private sidewalks, and driveway. Water Department approval of these drawings/sketches **must** be obtained **prior** to the commencement of any work.

- 11) Applicable permits must be obtained from the Building Commissioner's Office prior to commencement of any work.
- 12) All water service line work outside of the building shall be inspected by the Water Department prior to any backfill. To schedule an inspection with the Water Department, please call (314)984-5936.

TAP LOCATIONS AND SERVICE LINE ROUTING

- 1) Service lines shall enter buildings through the front wall. Exceptions to this rule **must** be obtained from the Water Department **prior** to construction.
- 2) Service lines shall be tapped to the water main on the street that runs along the **front** of the house and shall be located within the "shadow" of the house. Exceptions to this rule **may** be made by the Water Department **prior** to construction and **only** in cases in which
 - 1) the building is on a corner lot;
 - 2) the water main along the front of the building is on the opposite side of the street from the building;
 - 3) the water main on the side street is on the same side of the street as the building.The Water Department shall have final authority in determining which water main shall be tapped.
- 3) Drawings or sketches **must** be submitted to the Water Department **prior** to the commencement of any work. They shall indicate the proposed location of the service line, tap, curb box, meter box, and service line entry into the building. Drawings/sketches shall also indicate the existing location of the building, water main, curbs, street, public and private sidewalks, and driveway. Water Department approval of these drawings/sketches **must** be obtained **prior** to the commencement of any work.

CURB STOP VALVES

- 1) Curb stop valves shall be Mueller 300 ball curb valve B-25154 or Ford equivalent and shall have flare connections. Compression type connections are not permitted.
- 2) Curb stop "t-head" valves shall be the same diameter as the service line.
- 3) Curb stop valves shall have flare connections (both ends).
- 4) Curb stop valves shall be Minneapolis Pattern (no alternates).
- 5) Curb stop valves shall be in plain view from the top of the curb box with no dirt or other obstructions above it.
- 6) Curb stop valves shall be leak free upon installation.

- 7) Curb stop valves shall be threaded for connection to a Bingham & Taylor curb box #306.

CORPORATION STOPS

- 1) Corporation type shall be Mueller 300 Ball Type Corporation Valves, B-25000 Series or Ford equivalent.
- 2) Corporations, depending on service line requirements, shall be 1", 1-1/2", or 2" in diameter and shall be sized according to the service line diameter if the service line diameter is larger than one inch.
- 3) Contractor shall supply and install the proper size corporation corresponding with the service line size.
- 4) All connections to corporations shall be **straight flare only**. The use of swivel, solid quarter, or eighth bends are prohibited.
- 5) For 1-inch diameter corporation stops on PVCO pipe, corporation stops shall be ground key AWWA taper "CC" thread by copper flare eighth bend connection and shall be Mueller B-25000 or A.Y. McDonald 74701BL.
- 6) For existing cast iron pipe, one-inch corporation stops shall include dielectric nylon insulators, shall be Mueller N-35000 and shall include Mueller H-15064 eighth bend couplings.

CURB BOXES

- 1) Curb boxes shall be Bingham & Taylor #306 (no alternates). Curb boxes shall thread onto the curb stop valve. If bushings are required to attach the curb box to smaller curb stop valves, bushings shall be PVC or brass. Curb boxes shall be two-section telescoping PVC with a cast iron top and bolted lid.
- 2) Curb boxes shall be installed within the City right-of-way, between the street curb and sidewalk, and within the "shadow of the house". If a sidewalk does not exist, the curb box shall be installed two feet from the street curb. If the location of the water main prevents the curb box from being installed between the street curb and sidewalk, the curb box shall be installed on the building side of the sidewalk as close as possible to the walk.
- 3) Curb boxes shall be installed vertically and shall be perfectly centered over the curb stop valve.
- 4) Curb boxes shall never be installed in any sidewalk, or in a driveway in the area where the public sidewalk crosses the driveway.

- 5) Curb boxes shall be installed such that the top of the box is flush with the **dirty** surface. Curb boxes shall never pose a trip hazard or pose a potential threat of damage to lawn mowers.

SERVICE SADDLES

- 1) Service saddles for PVC pipe shall be bronze body Mueller H-13000 series, bronze body Ford 202BS, or bronze body A. Y. McDonald model 3805.

SERVICE LINE COUPLINGS

- 1) For existing service line connections, all copper-to-copper connections shall be either flared or silver soldered. Connections from copper to lead or galvanized service lines shall be made with a flare connection on the copper side and a compression connection on the lead or galvanized side.

WATER METER SIZING

- 1) All one-inch diameter service lines (new or replacement) shall have a minimum meter size of one-inch. There is no restriction with regard to the maximum diameter of a service line to a single-family residential dwelling.
- 2) For construction **other than** single-family residential dwellings, the meter diameter shall be no more than one size smaller than the service line in which it is being installed, in accordance with the following schedule:

<u>Service Line Diameter</u>	<u>Minimum Meter Diameter Allowed</u>
1"	1"
1 ¼"	1"
1 ½"	1"
2"	1 ½"
3"	2"
4"	3"
6"	4"
8"	6"

WATER METERS, 1"

- 1) Meters shall be 1" minimum diameter.
- 2) Meters and yokes shall be purchased from the City and installed by the contractor. In the event of service line replacements or repairs that require the replacement of the ¾" meter, the City shall provide a new 1" meter to the contractor and will bill the property owner the difference in cost between a ¾" meter and the actual meter installed.
- 3) The centerline of the meter connections shall be located no less than 14" and no more than 18" below the top of the meter box cover.

- 4) Meters/yokes shall be centered within the meter box.
- 5) Yokes shall be installed with the dielectric bushing on the building side.
- 6) Meters/yokes shall be leak free upon installation.

METER BOXES (FOR 1" METERS)

- 1) The cover of the meter box shall be such that the top of the box is flush with the **dirt** surface. Meter boxes shall never pose a trip hazard or pose a potential threat of damage to lawn mowers.
- 2) The frame shall be centered on the box.
- 3) The cover shall be the "drop in" type, non-locking, and shall **not** be predrilled for remote reading devices.
- 4) Meter boxes shall be **24"** min. diameter PVC.
- 5) Frames and covers shall be cast iron.
- 6) Meter boxes shall be located in the **front** yard within the "shadow" of the house. No exceptions.
- 7) Meter boxes shall not be permitted in driveways, sidewalks, or other paved areas. Meter boxes shall be located in a grass or otherwise landscaped area.
- 8) Meter boxes shall be located on private property, within ten feet of the property line.
- 9) Meter box extensions are not permitted on new construction.

WATER METERS, 1 ½ TO 2"

- 1) Meters shall be purchased from the City and installed by the contractor.
- 2) Meters shall be installed in a meter setter manufactured for **that** meter's particular size meter.
- 3) Meters shall be installed in a pyramid vault.
- 4) Meters shall be leak free upon installation.

METER SETTERS, 1 ½ TO 2"

- 1) The meter shall be installed in a meter setter, which shall hold the meter 18 inches above the level of the service line.

- 2) The setter shall be manufactured of copper and/or brass, with a lock-wing valve at each end of the meter. A bypass shall be provided beneath the meter, and shall be equipped with a lock-wing valve.
- 3) The bypass pipe diameter shall be 1" minimum for 1 ½" setters and 1 ½" minimum for 2" setters.
- 4) Only 1-½" meter setters shall be allowed for 1-½" meters. 1-½" meters shall not be installed in setters made for 2" meters. Adapters shall not be permitted to install 1-½" meters in 2" meter setters.
- 5) Dielectric fittings shall be installed on the building side of the meter setter.
- 6) 1-½ and 2" meter setters shall be supplied and installed by the contractor.

PYRAMID VAULTS (FOR 1 ½" TO 2" METERS)

- 1) Pyramid vaults shall be one-piece concrete.
- 2) The frame and cover shall be cast iron.
- 3) The cover **shall** be predrilled with a 1 ¾ inch diameter hole for future remote reading device installation.
- 4) The vault shall be placed on one **continuous** course of concrete (cinder) blocks.
- 5) A 12-inch thick base of 1" clean crushed limestone shall be placed beneath the pyramid vault.
- 6) Pyramid vaults shall be located in the **front** yard within the "shadow" of the building. No exceptions.
- 7) Pyramid vaults shall not be permitted in driveways, sidewalks, or other paved areas. Meter boxes must be located in a grass or otherwise landscaped area.
- 8) The cover of the pyramid vault shall be such that the top of the cover is flush with the **dirty** surface. Meter vaults shall never pose a trip hazard or pose a potential threat of damage to lawn mowers.
- 9) Pyramid vaults shall be located on private property, within ten feet of the property line.

WATER METERS, 3" AND LARGER

- 1) Meter shall be a new Schlumberger brand Neptune Tru/Flo compound meter ProRead ARB with pit receptacle and wiring. Meter shall measure in gallons.
- 2) A new Neptune brand strainer shall be bolted directly to the inlet of the meter.
- 3) The meter shall be installed directly beneath the vault opening.

- 4) Installation of the meter and strainer shall be performed by the contractor.
- 5) A collapsible fitting shall be installed by the contractor. It shall be installed between the meter and its downstream valve. This fitting shall allow the easy removal of gaskets, meter and strainer.
- 6) The meter shall be installed with a valved bypass of a diameter in accordance with the following schedule:

<u>Size of Meter</u>	<u>Size of Bypass</u>
3"	2"
4"	3"
6"	4"
8"	6"

LARGE METER VAULTS

- 1) Vaults shall be adequately sized to contain **all** piping, valves, bypass, fittings, meter and strainer associated with the meter installation.
- 2) Vaults for split services shall contain the domestic meter if the meter is 1-½ inch diameter or larger.
- 3) The meter shall be installed in a meter setter, which shall hold the meter 18 inches above the level of the service line.
- 4) The setter shall be manufactured of copper and/or brass, with a lock-wing valve at each end of the meter. A bypass shall be provided beneath the meter, and shall be equipped with a lock-wing valve.
- 5) The bypass pipe diameter shall be 1" minimum for 1 ½" setters and 1 ½" minimum for 2" setters.
- 6) Only 1-½" meter setters shall be allowed for 1-½" meters. 1-½" meters shall not be installed in setters made for 2" meters. Adapters shall not be permitted to install 1-½" meters in 2" meter setters.
- 7) If the meter is one-inch diameter on a split service, the meter shall be installed in a residential meter box located next to the vault.
- 8) All plumbing within the vault shall be ductile iron, copper or brass. All ductile iron pipe and all fittings shall be flanged. Steel or PVC piping or fittings are not permitted.
- 9) A minimum distance of 12 inches shall be maintained between any piping and 1) the vault floor and 2) the wall running parallel to piping.
- 10) Piping entering and exiting the vault shall have installed two (2) sets of socket clamps. Both sets of clamps shall be butted up against the exterior wall of the vault.

- 11) A 12-inch thick base of 1" clean crushed limestone shall be placed beneath the vault.
- 12) Vaults shall be located on private property, within 15 feet of the property line.
- 13) Vaults shall be located in the **front** yard and within the "shadow" of the building. No exceptions.
- 14) The top of the concrete vault shall be flush with the **dirt** surface. Vaults shall never pose a trip hazard or pose a potential threat of damage to lawn mowers.

TAP DESTROYS

- 1) Water taps shall be destroyed prior to the issuance of a building demolition permit (no exceptions).
- 2) The service line shall be cut at the back of the flare nut.
- 3) Water Department personnel **must** inspect a tap destroy prior to backfill.

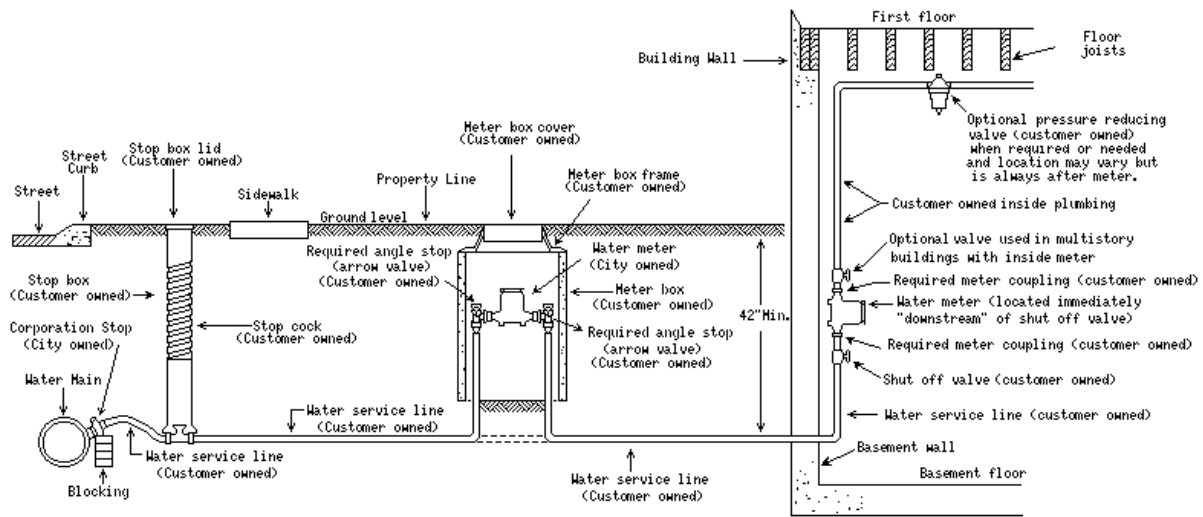

NOTE: This drawing illustrates both outside and inside meter settings.

KIRKWOOD WATER DEPARTMENT
1" SERVICE CONNECTIONS
Tap Hole Dimensions and Conditions

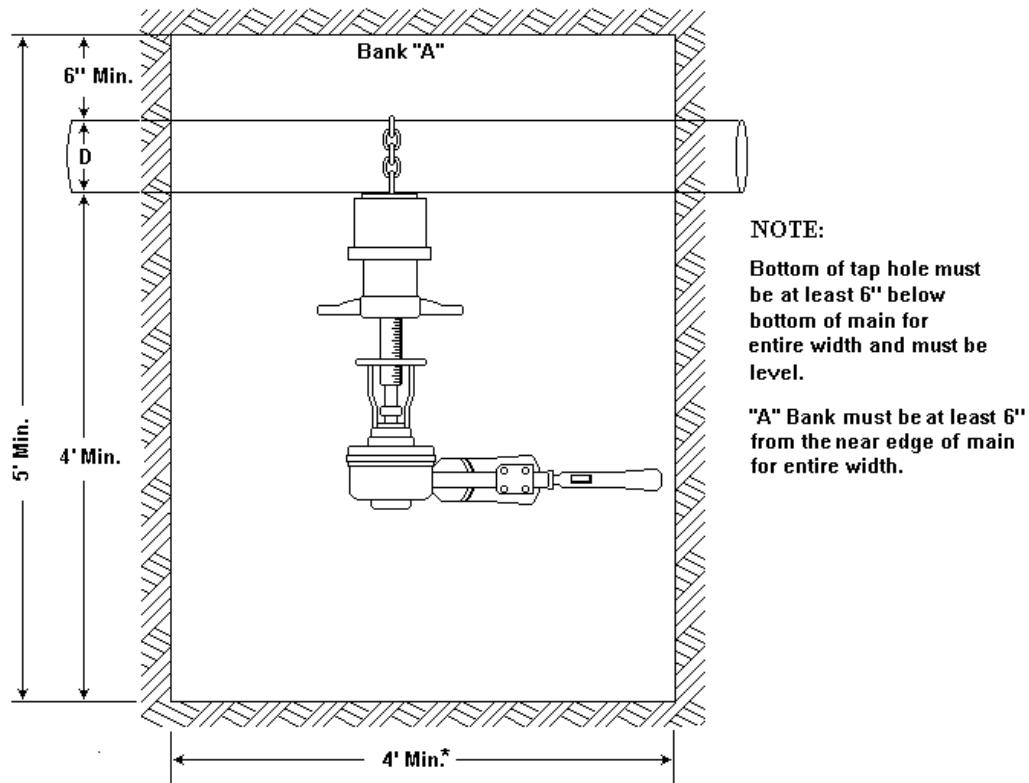

General Rules

1. "D" Dimension (main size) is variable.
- *2. If pipe joint, valve, clamp, coupling, existing tap, or any other interruption in clean, straight, smooth, continuous pipeline is visible in excavation, call 984-5936 for review before completing excavation. Taps shall not be closer than 18" to nearest part of joint, valve, clamp, coupling, existing tap, or any other interruption in clean, straight, smooth, continuous pipeline.
3. Tap hole shall be free of water and mud.
4. Pipeline must be clean enough to repair or rewrap any damage to Polywrap.
5. The excavation must comply with all applicable OSHA regulations.

KIRKWOOD WATER DEPARTMENT
1 1/2" - 2" SERVICE CONNECTIONS
Tap Hole Dimensions and Conditions

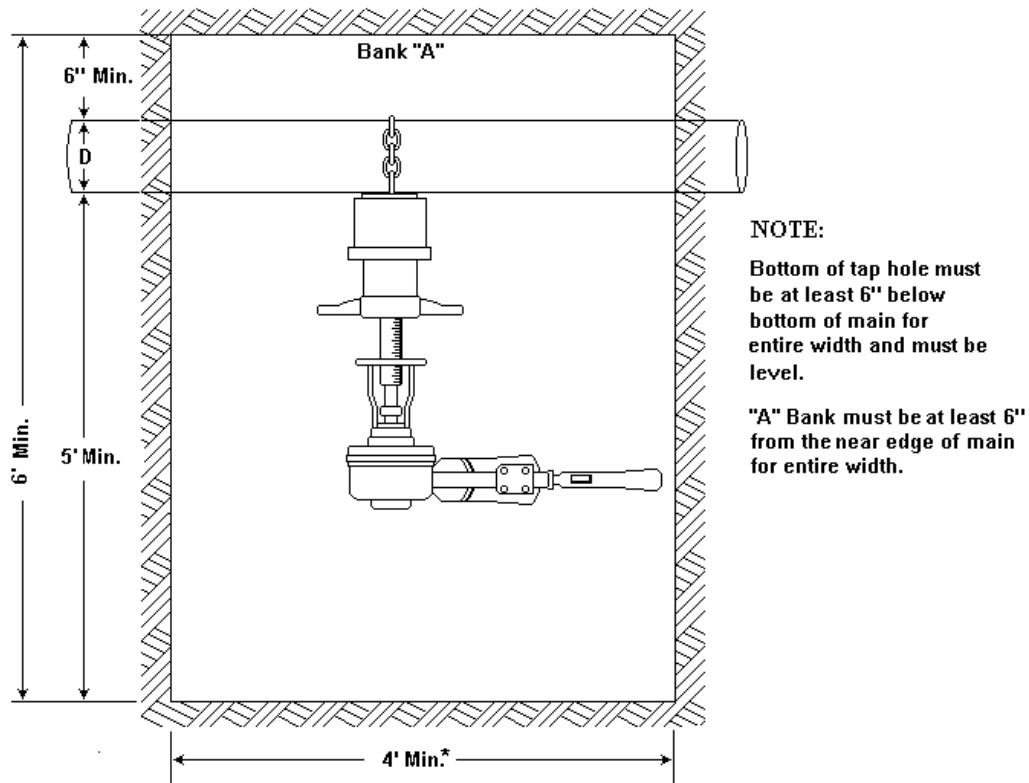

General Rules

1. "D" Dimension (main size) is variable.
- *2. If pipe joint, valve, clamp, coupling, existing tap, or any other interruption in clean, straight, smooth, continuous pipeline is visible in excavation, call 984-5936 for review before completing excavation. Taps shall not be closer than 18" to nearest part of joint, valve, clamp, coupling, existing tap, or any other interruption in clean, straight, smooth, continuous pipeline.
3. Tap hole shall be free of water and mud.
4. Pipeline must be clean enough to repair or rewrap any damage to Polywrap.
5. The excavation must comply with all applicable OSHA regulations.